

---

## To the Owner

Thank you for selecting a outboard motor. This Owner's Manual contains information needed for proper operation, maintenance and care. A thorough understanding of these simple instructions will help you obtain maximum enjoyment from you. If you have any question about the operation or maintenance of your outboard motor, please consult a dealer.

In this Owner's Manual particularly important information is distinguished in the following ways.



: This is the safety alert symbol. It is used to alert you to potential personal injury hazards. Obey all safety message that follow this symbol to avoid possible injury or death.



A WARNING indicated a hazardous situation which ,if not avoided, could result in death or serious injury.

### **NOTICE:**

A NOTICE indicated special precautions that must be taken to avoid damage to the outboard motor or other property.

### **TIP:**

A TIP Provides key information to make procedures easier or clearer.

We continually seeks advancements in product design and quality. Therefore, while this manual contains the most current product information available at the time of printing, there may be minor discrepancies between your machine and this manual. If there is any question concerning this manual, please consult your dealer.

To ensure long product life, We recommends that you use the product and maintenance by correctly following the instructions in the owner's manual. Any damage resulting from neglect of these instructions is not covered by warranty.

Some countries have laws or regulations restricting users from taking the product out of the country where it was purchased, and it may be impossible to register the product in the destination country. Additionally, the warranty may not apply in certain regions. When planning to take the product to another country, consult the dealer where the product was

---

purchased for further information.

If the product was purchased used, please consult your closet dealer for customer registration and to be eligible for the specified services.

**Tip:**

The F50FETL, F60FETL, F70FETL, F50BETL, F60BETL, F70BETL and the standard accessories are used as a base for the explanations and illustrations in this manual.

Therefore some items may not apply to every model.

---

## Table of Contents

1. Safety information.....	1
2. General information.....	7
3. Specifications and requirements.....	11
4. Components .....	18
5. Instruments and indicators.....	32
6. Engine control system.....	34
7. Installation.....	36
8. Operation.....	38
9. Maintenance.....	64
10. Trouble recovery.....	92

---

## Safety information

Observe these precautions at all times.

### **Propeller**

People can be injured or killed if they come in contact with the propeller. The propeller can keep moving even when the motor is in neutral, and sharp edges of the propeller can cut even when stationary.

- Stop the engine when a person is in the water near you .
- Keep people out of reach of the propeller, even when the engine is off.

### **Rotating parts**

Hands, feet, hair, jewelry, clothing, personal flotation device(PFD) straps, etc. can become entangled with internal rotating parts of the engine, resulting in serious injury or death.

Keep the top cowling in place whenever possible. Do not remove or replace the cowling with the engine running.

Only operate the engine with the cowling removed according to the specific instructions in the manual. Keep hands, feet, hair, jewelry, clothing, PFD straps, etc. away from any exposed moving parts.

### **Hot parts**

During and after operation, engine parts are hot enough to cause burns. Avoid touching any parts under the top cowling until the engine has cooled.

### **Electric shock**

Do not touch any electrical parts while starting or operating the engine. They can cause shock or electrocution.

### **Power trim and tilt**

Body parts can be crushed between the motor and the clamp bracket when the motor is trimmed or tilted. Keep body parts out of this area at all times. Be sure no one is in this area before operating the power trim and tilt mechanism.

The power trim and tilt switches operate even when the main switch is off. Keep people be away from the switches whenever working around the motor.

Never get under the lower unit while it is tilted, even when the tilt support lever is locked.

Severe injury could occur if the outboard motor accidentally falls.

---

## **Engine shut-off cord (lanyard)**

Attach the engine shut-off cord so that the engine stops if the operator falls overboard or leaves the helm. This prevents the boat from running away under power and leaving people stranded, or running over people or objects.

Always attach the engine shut-off cord to a secure place on your clothing or your arm or leg while operating. Do not remove it to leave the helm while the boat is moving. Do not attach the cord to clothing that could tear loose, or route the cord where it could become entangled, preventing it from functioning.

Do not route the cord where it is likely to be accidentally pulled out. If the cord is pulled during operation, the engine will shut off and you will lose most steering control. The boat could slow rapidly, throwing people and objects forward.

## **Gasoline**

**Gasoline and its vapors are highly flammable and explosive.** Always, refuel according to the procedure on request to reduce the risk of fire and explosion.

### **Gasoline exposure and spills**

Take care not to spill gasoline. If gasoline spills, wipe it up immediately with dry rags.

Dispose of rags properly.

If any gasoline spills onto your skin, immediately wash with soap and water. Change clothing if gasoline spills on it.

If you swallow gasoline, inhale a lot of gasoline vapor, or get gasoline in your eyes, get immediate medical attention. Never siphon fuel by mouth.

## **Carbon monoxide**

This product emits exhaust gases which contain carbon monoxide, a colorless, odorless gas which may cause brain damage or death when inhaled. Symptoms include nausea, dizziness, and drowsiness. Keep cockpit and cabin areas well ventilated. Avoid blocking exhaust outlets.

## **Modifications**

Do not attempt to modify this outboard motor. Modifications to your outboard motor may reduce safety and reliability, and render the outboard unsafe or illegal to use.

---

## **Boating safety**

This section includes a few of the many important safety precautions that you should follow when boating.

### **Alcohol and drugs**

Never operate after drinking alcohol or taking drugs. Intoxication is one of the most common factors contributing to boating fatalities.

### **Personal flotation devices(PFDs)**

Have an approved PFD on board for every occupant. We recommends that you must wear a PDF whenever boating. At a minimum, children and non-swimmers should always wear PFDs, and everyone should wear PFDs when there are potentially hazardous boating conditions.

### **People in the water**

Always watch carefully for people in the water, such as swimmers, skiers, or divers, whenever the engine is running. When someone is in the water near the boat, shift into neutral and stop the engine.

Stay away from swimming areas. Swimmers can be hard to see.

The propeller can keep moving even when the motor is in the neutral. Stop the engine when a person is in the water near you.

### **Passengers**

Consult your boat manufacturer's instructions for details about appropriate passenger locations in your boat and be sure all passengers are positioned properly before accelerating and when operating above an idle speed. Standing or sitting in non-designated locations may result is being thrown either overboard or within the boat due to waves, wakes, or sudden changes in speed or direction. Even when people are positioned properly, alert your passengers if you must make any unusual maneuver. Always avoid jumping waves or wakes.

### **Overloading**

Do not overload the boat. Consult the boat capacity plate or boat manufacturer for maximum weight and number of passengers. Be sure that weight is properly distributed according to the boat manufacturer's instructions. Overloading or incorrect weight distribution can compromise the boats handling and lead to an accident, capsizing or

swamping.

### **Avoid collisions**

Scan constantly for people, objects, and other boats. Be alert for conditions that limit your visibility or block your vision of others.

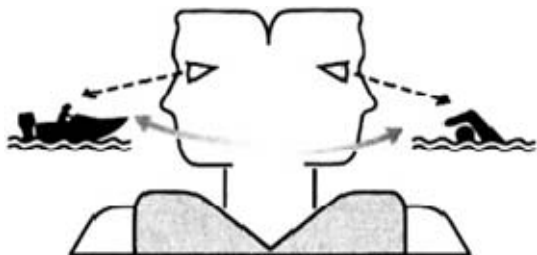

Operate defensively at safe speeds and keep a safe distance away from people, objects, and other boats.

- Do not follow directly behind other boats or waterskiers.
- Avoid sharp turns or other maneuvers that make it hard for others to avoid you or understand where you are going.
- Avoid areas with submerged objects or shallow water.
- Ride within your limits and avoid aggressive maneuvers to reduce the risk of loss of control, ejection, and collision.
- Take early action to avoid collisions. Remember, boats do not have brakes, and stopping the engine or reducing throttle can reduce the ability to steer. If you are not sure that you can stop in time before hitting an obstacle, apply throttle and turn in another direction.

### **Passenger training**

Make sure at least one other passenger is trained to operate the boat in the event of an emergency.

### **Boating safety publications**

Be informed about boating safety. Additional publications and information can be obtained from many boating organizations.

### **Laws and regulations**

Know the marine laws and regulations where you will be boating and obey them. Several sets of rules prevail according to geographic location, but all are basically the same as the international Rules of the Road.

## General information

### Identification numbers record

#### Outboard motor serial number

The outboard motor serial number is stamped on the label attached to the port side of the clamp bracket.

Record your outboard motor serial number in the spaces provided to assist you in ordering spare parts from your dealer or for reference in case your outboard motor is stolen.

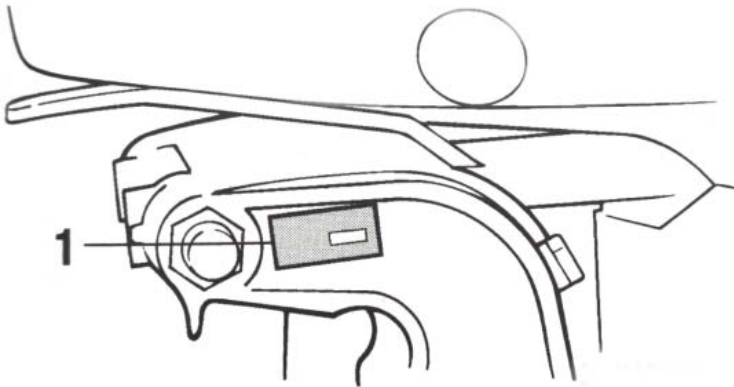

#### 1. Outboard motor serial number location

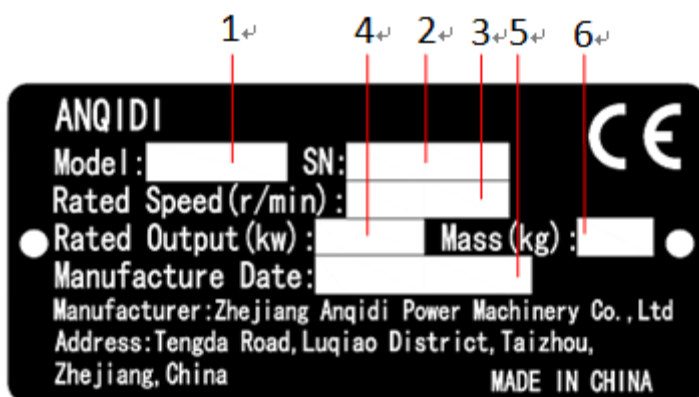

1. Model name
2. Serial number
3. Rated speed
4. Rated power
5. Manufacture Date
6. Weight



## Read manual and labels

Before operating or working on this outboard motor:

- Read this manual.
- Read any manuals supplied with the boat.
- Read all labels on the outboard motor and the boat.

If you need any additional information, contact your dealer.

### Warning labels

If these labels are damaged or missing, contact your dealer for replacements.

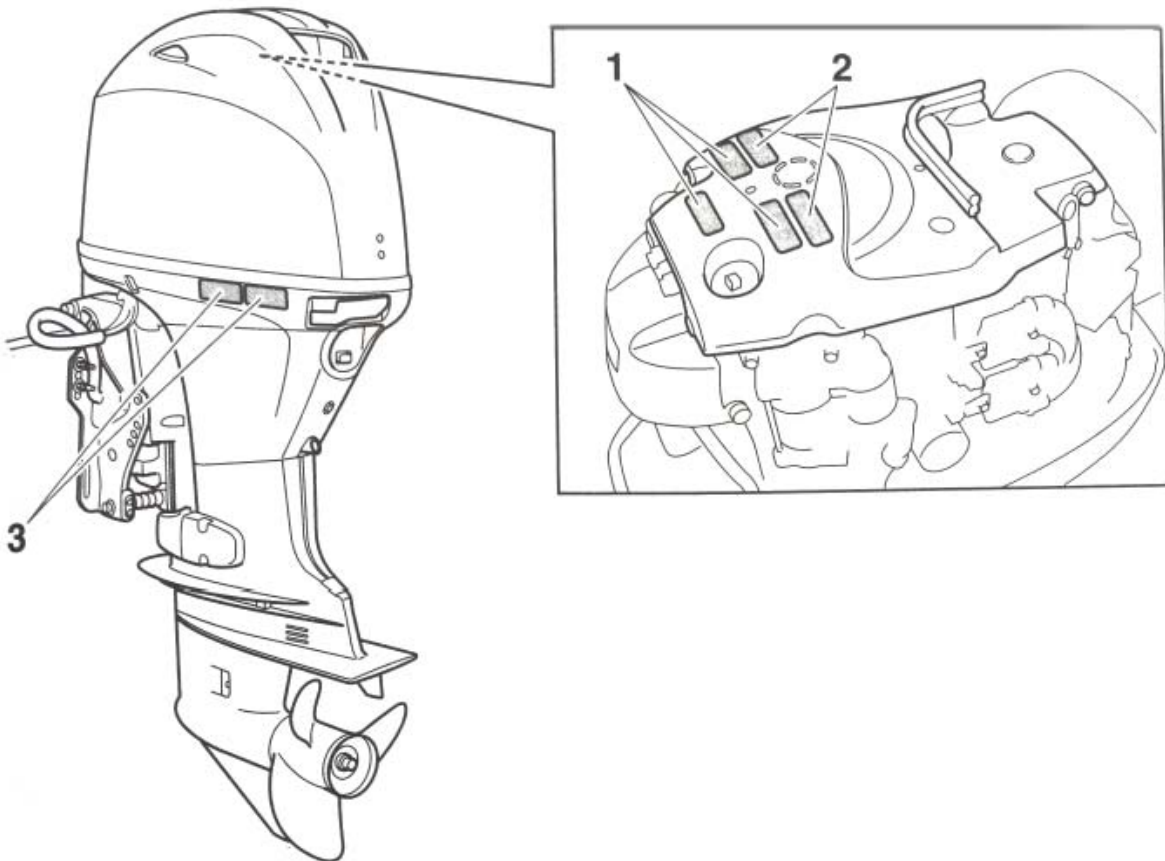

1



2

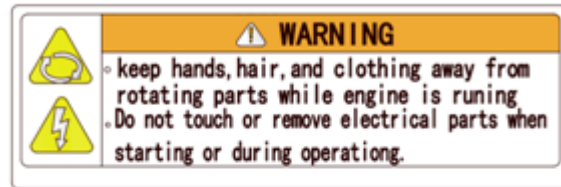

3

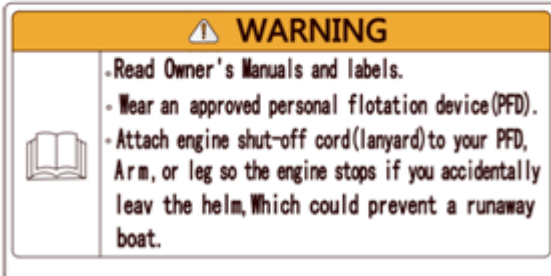

### Contents of labels

The above warning labels mean as follows.

1. **⚠ WARNING** Emergency starting does not have start-in-gear protection. Ensure shift control is in neutral before starting engine.

2. **⚠ WARNING** Keep hands, hair, and clothing away from rotating parts while the engine is running.

Do not touch or remove electrical parts when starting or during operation.

3. **⚠ WARNING**

- Read Owner's Manuals and labels.
- Wear an approved personal flotation device (PFD)
- Attach engine shut-off cord (lanyard) to your PFD, arm, or leg so the engine stops if you accidentally leave the helm, which could prevent a runaway boat.

## Symbols

The following symbols mean as follows.

Notice/Warning



Read Owner's Manual

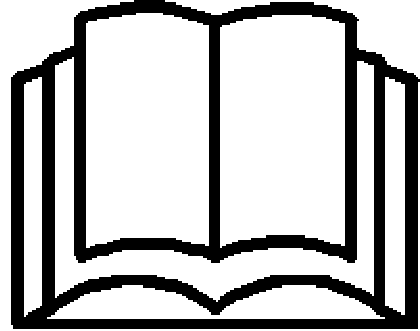

Hazard caused by continuous rotation



Electrical hazard



# Specifications and requirements

## Specifications

### TIP:

“AL” stated in the specification data below represents the numerical value for the aluminum propeller installed.

### Dimension and weight:

Overall length: 65.0×75.0 mm (2.56×2.95 in)

689mm (27.5 in)

Overall width:

386mm (15.2 in)

Overall height L:

1435mm (56.5 in)

Motor transom height L:

527mm (20.7 in)

Dry weight (AL) L:

113KG (249 lb)

Ignition system:

TCI

Spark plug (NGK):

DPR6EB-9

Spark plug gap:

0.8-0.9 mm (0.031-0.035 in)

Steering system:

Remote steering

Tiller handle

Starting system:

Electric starter

Manual starter

Starting carburetion system:

Fuel injection

Valve clearance IN (cold engine):

0.15-0.25 mm (0.0059-0.0098 in)

Valve clearance EX (cold engine):

0.25-0.35 mm (0.0098-0.0138 in)

Battery rating (CCA/EN):

430-1080 A

Battery rating (20HR/1EC):

70 Ah

Maximum generator output:

15A (F70)

16A (F60,F50)

### Performance:

Full throttle operating range:

5000-6000 r/min

Rate power:

36.8KW (50 HP)

44.1 KW (60HP)

51.5 KW (70HP)

Idle speed (in neutral):

700-800 r/min

### Power unit:

Type:

4-stroke SOHC 2L 8 valves

Total displacement:

996 cm<sup>3</sup> (60.8 c.i. )

Bore×stroke:

---

**Lower unit**

Gear shift positions:

Forward-neutral-reverse

Gear ratio:

1.85 (24/13)

Trim and tilt system:

Propeller mark:

G

**Fuel and oil:**

Recommended fuel:

Regular unleaded gasoline

Min.pump octane unumber(PON):

86

Min. research octane number (RON):

90

Fuel tank capacity:

24 L (6.34 US gal. 5.28 Imp. gal)

Recommended engine oil:

4-stroke outboard motor oil

Recommended engine oil grade 1:

SAE 10W-30/10W-40/5W-30

API SE/SF/SG/SH/SJ/SL

Engine oil quantity (without oil filter replacement):

1.9 L (2.01 US qt, 1.67 Imp. qt)

Engine oil quantity (with oil filter replacement):

2.1 L (2.22 US qt, 1.85 Imp. qt)

Lubrication system:

Wet sump

Recommended gear oil:

Hypoid gear oil

Recommended gear oil grade:

SAE 90 API GL-4

Gear oil quantity:

0.430 L (0.455 US qt)

0.378 (Imp. qt)

Tightening torque:

Spark plug:

17 Nm (1.73 kgf-m, 12.5 ft-lb)

Propeller nut:

34 Nm (3.47 kgf-m, 25.1 ft-lb)

Engine oil drain bolt:

27 Nm (2.75 kgf-m, 19.9 ft-lb)

Engine oil filter:

18 Nm (1.84 kgf-m, 13.3 ft-lb)

## Installation requirements:

### Boats horsepower rating



**Overpowering a boat can cause severe instability.**

Before installing the outboard motor(s), confirm that the total horsepower of your outboard motor(s) does not exceed the boat's maximum horsepower rating. See the boat's capacity plate or contact the manufacturer.

### Mounting motor



- **Improper mounting of the outboard motor could result in hazardous conditions, such as poor handling, loss of control, or fire hazards.**
- **Because the motor is very heavy, special equipment and training is required to mount it safely.**

Your dealer or other person experienced in proper rigging should mount the motor using correct equipment and complete rigging instructions.

## Remote control requirements



- **If the engine starts in gear, the boat can move suddenly and unexpectedly, possibly causing a collision or throwing passengers overboard.**
- **If the engine ever starts in gear, the start-in-gear protection device is not working correctly and you should discontinue using the outboard. Contact your dealer.**

The remote control unit must be equipped With a start-in-gear protection device(s). This device prevents the engine from starting unless it is in neutral.

## Battery requirements

### Battery specifications

Battery rating (CCA/EN):

430-1080 A

Battery rating (20HR/IEC):

70 Ah

---

The engine cannot be started if battery voltage is too low.

### **Mounting battery**

Mount the battery holder securely in a dry, well-ventilated, vibration-free location in the Boat.

**WARNING! Do not put flammable items, or loose heavy or metal objects in the same compartment as the battery. Fire, explosion or sparks could result.**

### **Battery cable**

The battery cable size and length are critical. Consult your dealer about the battery cable size and length.

### **Multiple batteries**

To connect multiple batteries, such as for multiple engine configurations or for an accessory battery, consult your dealer about battery selection and correct wiring.

### **Battery isolator**

Your outboard motor is capable of charging an accessory battery separate from the starting battery using an optional isolator lead. Contact your dealer for installation of an optional isolator lead with over-current protection.

## **Propeller selection**

Next to selecting an outboard motor, selecting the right propeller is one of the most important purchasing decisions a boater can make. The type, size and design of your propeller have a direct impact on acceleration, top speed, fuel economy, and even engine life. We design and manufacture propellers for every outboard motor and every application.

Your dealer can help you select the right propeller for your boating needs. Select a propeller that will allow the engine to reach the middle or upper half of the operating range at full throttle with the maximum boatload. Generally, select a larger pitch propeller for a smaller operating load and a smaller pitch propeller for a heavier load. If you carry loads that vary widely, select the propeller that lets the engine run in the proper range for your maximum load but remember that you may need to reduce your throttle setting to stay within the recommended engine speed range when carrying lighter loads.

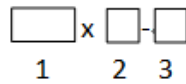
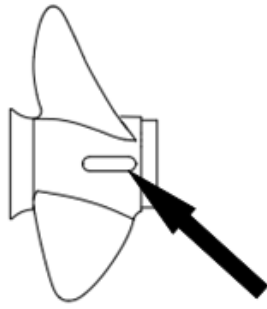

1. Propeller diameter in inches
2. Propeller pitch in inches
3. Type of propeller (propeller mark)

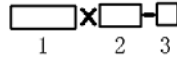
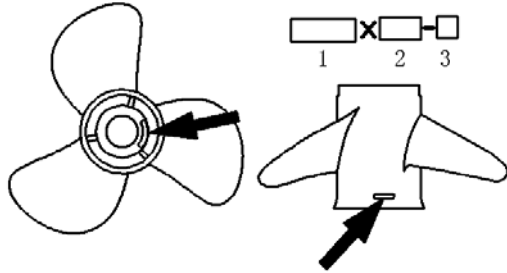

1. Propeller diameter in inches
2. Propeller pitch in inches
3. Type of propeller (propeller mark)

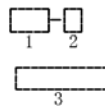
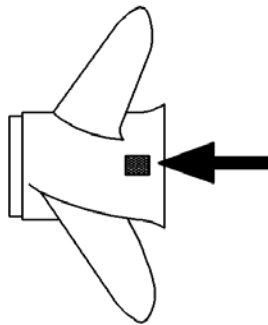

1. Propeller diameter in inches
2. Type of propeller (propeller mark)
3. Propeller pitch in inches

### Start-in-gear protection

Our outboard motors or our approved remote control units are equipped with start-in-gear protection device(s). This feature permits the engine to be started only when it is in neutral. Always select neutral before starting the engine

### Engine oil requirements

Select an oil grade according to the average temperatures in the area where the outboard motor will be used.

**Recommended engine oil:** 4-stroke outboard motor oil

**Recommended engine oil grade 1:** SAE 10W-30/10W-40/5W-30

API SE/SF/SG/SH/SJ/SL

**Recommended engine oil grade 2:** SAE 15W-40/20W-40/20W-50

API SH/SJ/SL

**Engine oil quantity (without oil filter replacement):** 1.9L (2.01 US qt, 1.67 Imp. qt)

**Engine oil quantity (with oil filter replacement):** 2.1L (2.22 US qt, 1.85 Imp. qt)



If oil grades listed under Recommended engine oil grade 1 are not available, select an alternative oil grade listed under Recommended engine oil grade 2.

#### Recommended engine oil grade 1

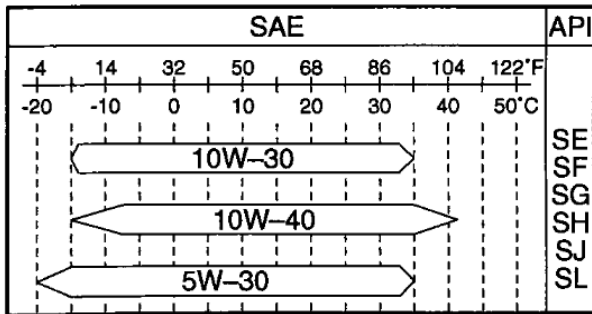

#### Recommended engine oil grade 2

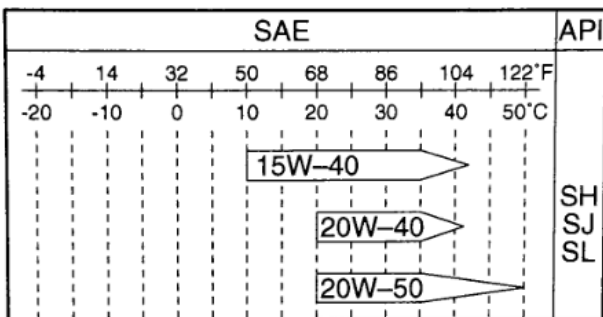

## Fuel requirements

### Gasoline

Use a good quality gasoline that meets the minimum octane rating. If knocking or pinging occurs, use a different brand of gasoline or premium unleaded fuel. Our recommends that you use alcohol-free (see Gasohol)gasoline whenever possible.

**Recommended fuel:** Regular unleaded gasoline

**Min. research octane number (RON):**90

### NOTICE

- Do not use leaded gasoline. Leaded gasoline can seriously damage the engine.
- Avoid getting water and contaminants in the fuel tank. Contaminated fuel can cause poor performance or engine damage. Use only fresh gasoline that has been stored in clean containers.

### Gasohol

There are two types of gasohol: gasohol containing ethanol (E10) and that containing

---

methanol. Ethanol can be used if the ethanol content does not exceed 10% and the fuel meets the minimum octane ratings. All ethanol blends containing more than 10% ethanol can cause fuel system damage or cause engine starting and running problems.

We do not recommend gasohol containing methanol because it can cause fuel system damage or engine performance problems.

### **Muddy or acidic water**

We strongly recommends that you have your dealer install optional chromium plated water pump kit if you use the outboard motor in muddy or acidic water conditions. However, depending on the model it might not be required.

### **Anti-fouling paint**

A clean hull improves boat performance. The boat bottom should be kept as clean of marine growth as possible. If necessary, the boat bottom can be coated with an anti-fouling paint approved for your area to inhibit marine growth.

Do not use anti-fouling paint which includes copper or graphite. These paints can cause more rapid engine corrosion.

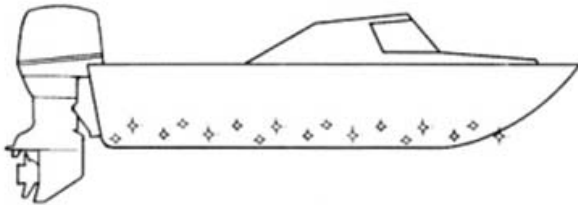

## **Motor disposal requirements**

Never illegally discard (dump) the motor. We recommend consulting the dealer about discarding the motor.

## **Emergency equipment**

Keep the following items onboard in case there is trouble with the outboard motor.

- A tool kit with assorted screwdrivers, pliers, wrenches (including metric sizes), and electrical tape.
- Waterproof flashlight with extra batteries.
- An extra engine shut-off cord (lanyard) with clip.
- Spare parts, such as an extra set of spark plugs.

Consult your dealer for dealer for detail.

---

## Components

### Components diagram

#### TIP:

\* May not be exactly as shown; also may not be included as standard equipment on all models (order from dealer).

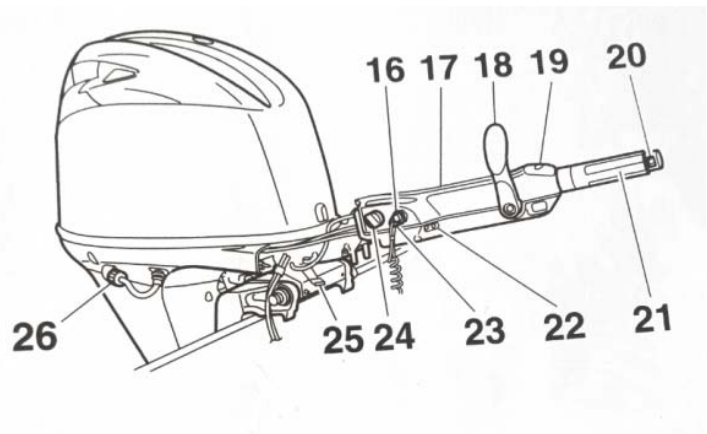
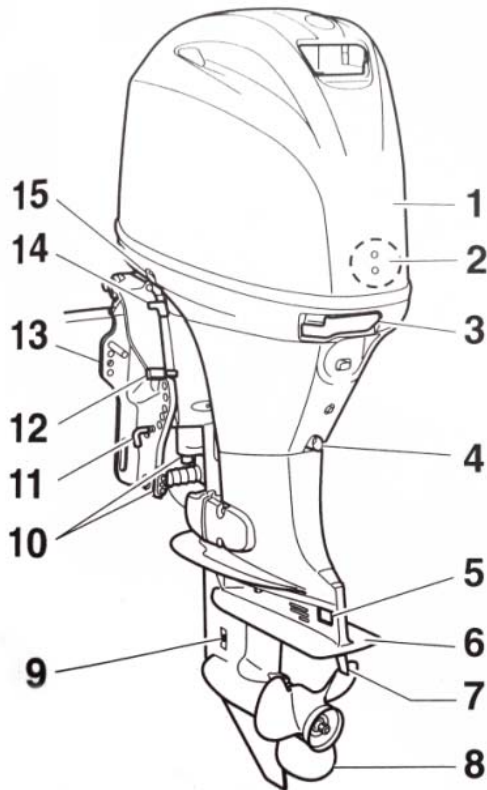

1. Top cowling

2. Water separator

3. Cowling lock lever

4. Drain screw

5. Anode\*

6. Anti-cavitation plate

7. Trim tab (anode)

8. Propeller\*

9. Cooling water inlet

10. Anode(s)\*

11. Trim rod\*

12. Tilt lock lever\*

13. Clamp bracket

14. Tilt support lever

15. Power trim and tilt switch\*

16. Engine stop button/Engine shut-off switch

17. Tiller handle

18. Gear shift lever\*

19. Variable trolling RPM switch\*

20. Power trim and tilt switch\*

21. Throttle grip\*

22. Alert indicator\*

23. Clip\*

24. Main switch\*

25. Steering friction adjuster\*

26. Flushing device

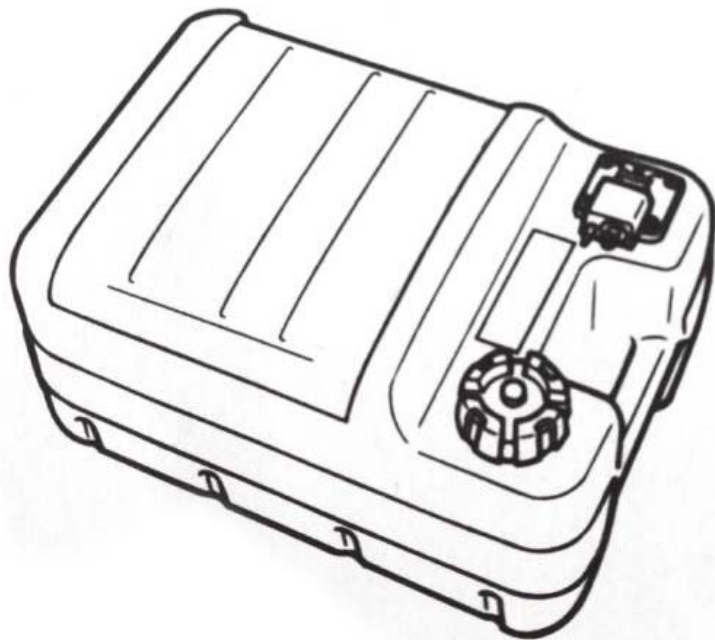
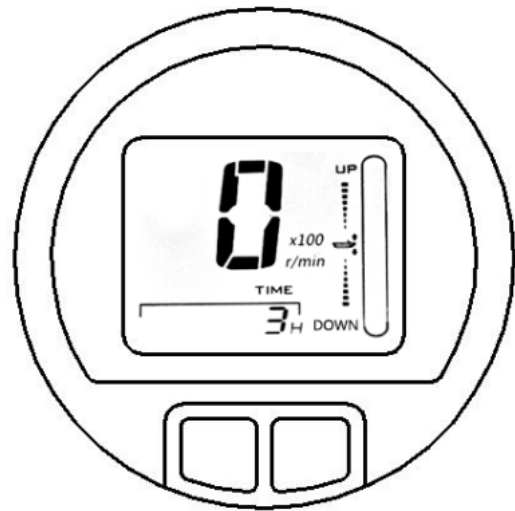
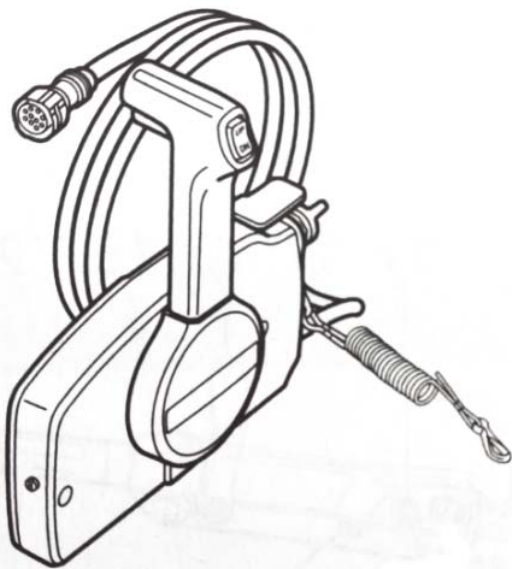

1. Remote control box (side mount type)
2. Digital tachometer
3. Fuel tank

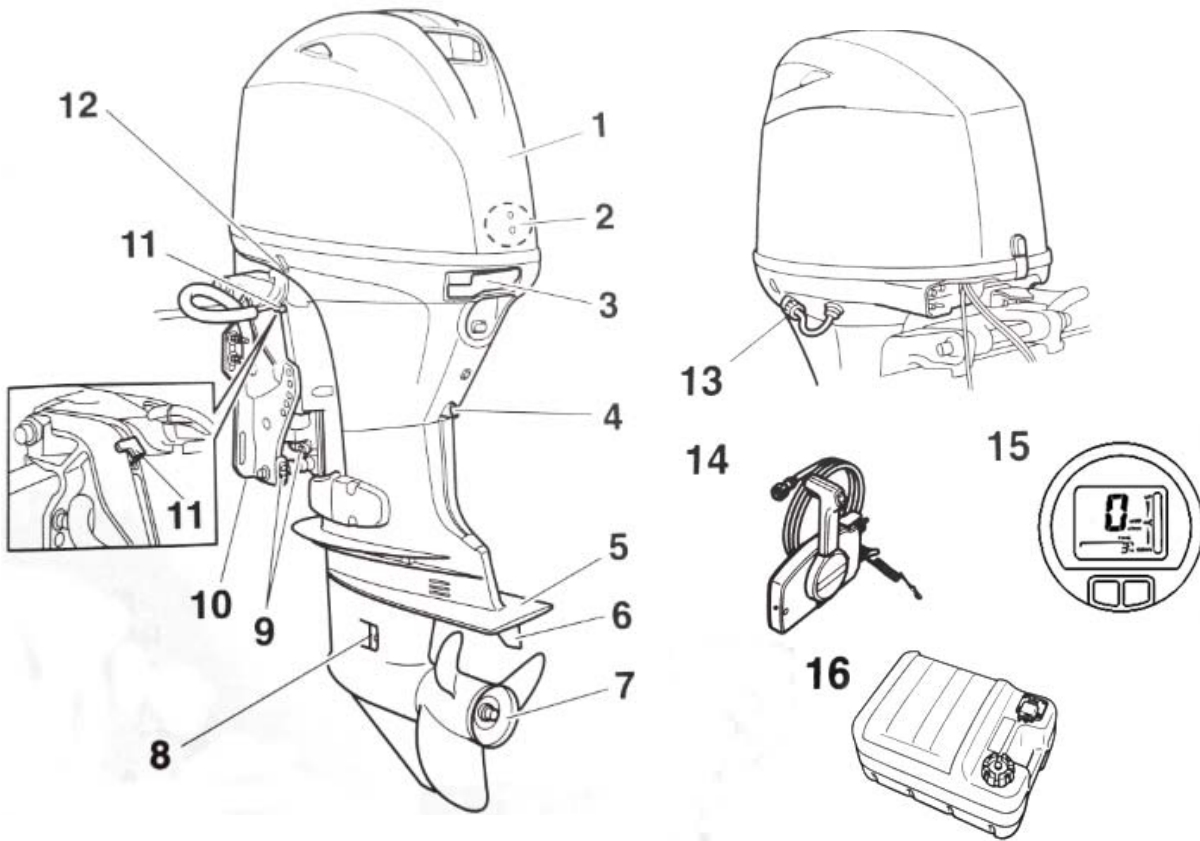

1. Top cowling
2. Water separator
3. Cowling lock lever
4. Drain screw
5. Anti-cavitation plate
6. Trim tab (anode)
7. Propeller
8. Cooling water inlet
9. Anode(s)
10. Clamp bracket
11. Tilt support lever
12. Power trim and tilt switch
13. Flushing device
14. Flushing control box (side mount type)
15. Digital tachometer
16. Fuel tank\*

---

## Fuel tank (portable fuel tank)

This model can be equipped with an optional portable fuel tank.

The type of portable fuel tank that is available varies according to local laws or regulations

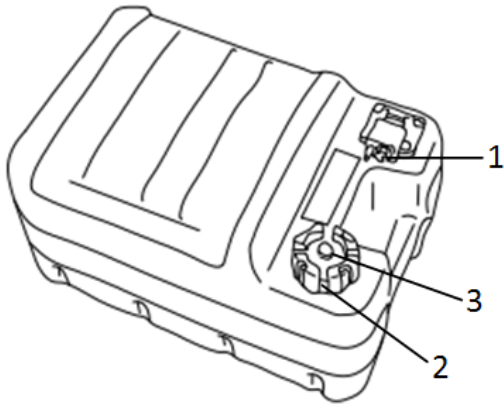

1. Fuel tank
2. Fuel tank cap
3. Air vent screw

## WARNING

The fuel tank supplied with this engine is its dedicated fuel reservoir and must not be used as a fuel storage container. Commercial users should conform to relevant licensing or approval authority regulations.

## Fuel joint

This joint is used to connect the fuel line.

## Air vent screw

This screw is on the fuel tank cap. When turning the air vent screw counterclockwise.

## Fuel tank cap

This cap seals the fuel tank. When removed, the tank can be filled with fuel. To remove the cap, turn it counterclockwise.

## Remote control box

The remote control lever actuates both the shifter and the throttle. The electrical switches are mounted on the remote control box.

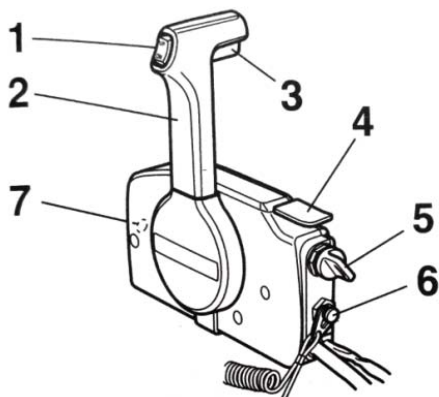

1. Power trim and tilt switch
2. Remote control lever
3. Neutral interlock trigger
4. Neutral throttle lever
5. Main switch
6. Engine shut-off switch
7. Throttle friction adjuster

---

## Remote control lever

Moving the lever forward from the neutral position engages forward gear. Pulling the lever back from neutral engages reverse. The engine will continue to run at idle until the lever is moved about 35° (a detent can be felt). Moving the lever farther opens the throttle, and the engine will begin to accelerate.

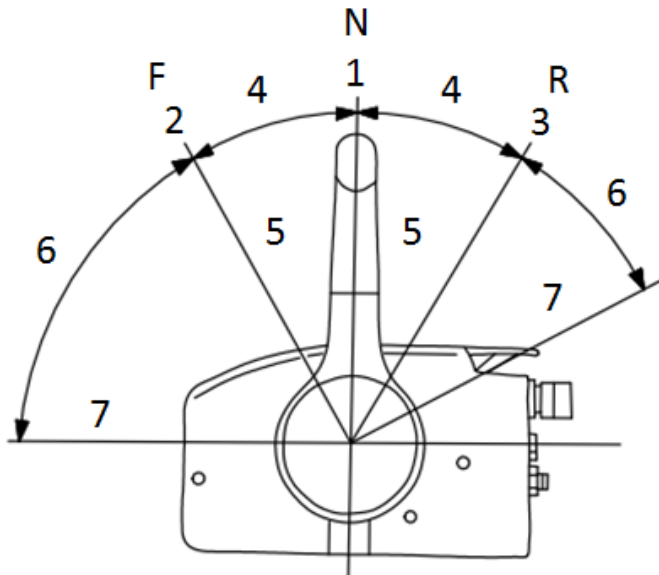

- Neutral "N"
- Forward "F"
- Reverse "R"
- Shift
- Fully closed
- Throttle
- Fully open

## Neutral interlock trigger

To shift out of neutral, first pull the neutral interlock up.

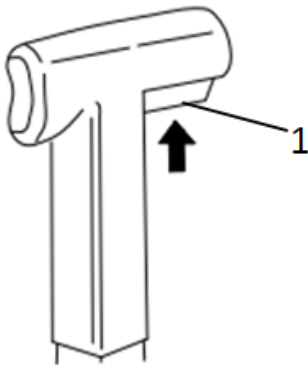

1. Neutral interlock trigger

## Neutral throttle lever

To open the throttle without shifting into either forward or reverse, put the remote control lever in the neutral position and lift the neutral throttle lever.

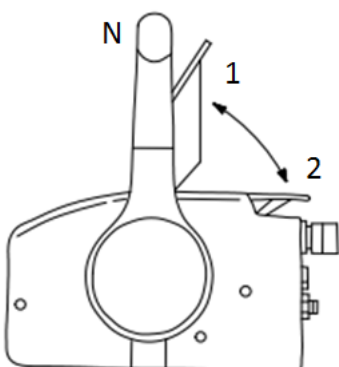

1. Fully open.
2. Fully closed

---

**TIP:**

The neutral throttle lever will operate only when the remote control is in neutral. The remote control lever will operate only when the neutral throttle lever is in the closed position.

**Tiller handle**

To change direction, move the tiller handle to the left or right as necessary.

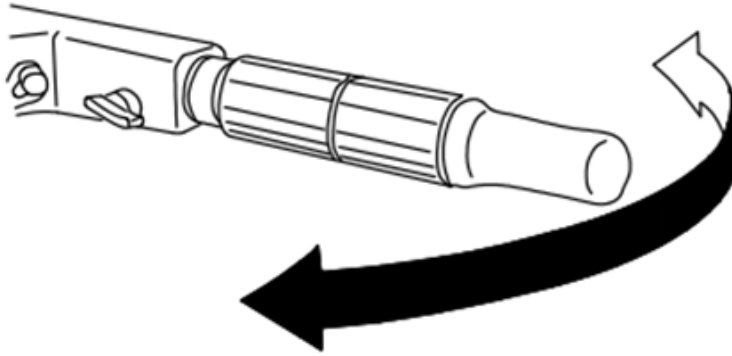

**Gear shift lever**

Move the gear shift lever forward to engage the forward gear or rearward to engage the reverse gear.

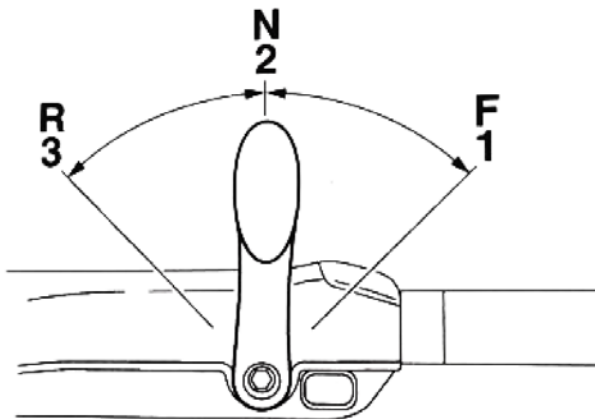

1. Forward "F"
2. Neutral "N"
3. Reverse "R"

**Throttle grip**

The throttle grip is on the tiller handle. Turn the grip counterclockwise to increase speed and clockwise to decrease speed.

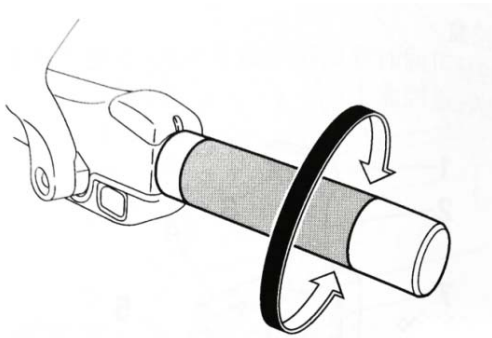



---

## Throttle indicator

The fuel consumption curve on the throttle indicator shows the relative amount of fuel consumed for each throttle position. Choose the setting that offers the best performance and fuel economy for the desired operation.

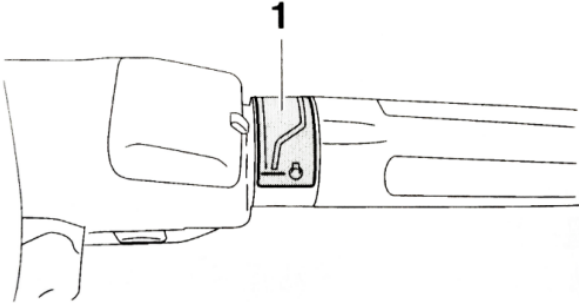

1. Throttle indicator

## Throttle friction adjuster

A friction device provides adjustable resistance to movement of the throttle grip or the remote control lever, and can be set according to operator preference.

To increase resistance, turn the adjuster clockwise. To decrease resistance, turn the adjuster counterclockwise. **WARNING!** Do not overtighten the friction adjuster. If there is too much resistance, it could be difficult to move the remote control lever or throttle grip, which could result in an accident.

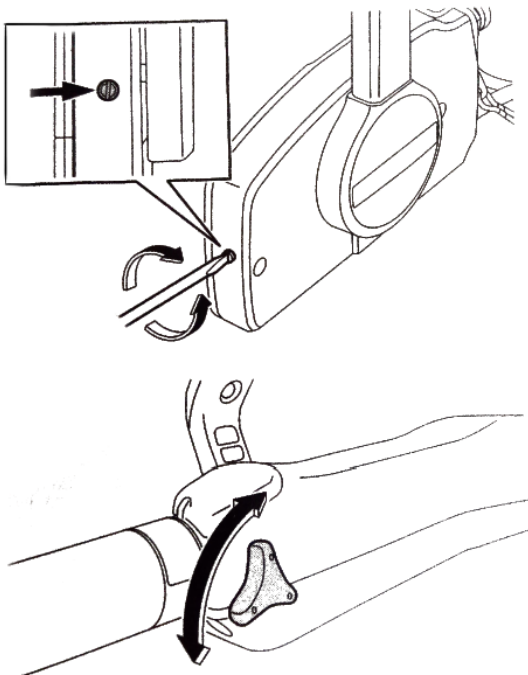

When constant speed is desired, tighten the adjuster to maintain the desired throttle setting.

---

## Engine shut-off cord (lanyard) and clip

The clip must be attached to the engine shut-off switch for the engine to run. The cord should be attached to a secure place on the operator's clothing, or arm or leg. Should the operator fall overboard or leave the helm, the cord will pull out the clip, stopping ignition to the engine. This will prevent the boat from running away under power. **WARNING! Attach the engine shut-off cord to a secure place on your clothing, or your arm or leg while operating. Do not attach the cord to clothing that could tear loose. Do not route the cord where it could become entangled, preventing it from functioning. Avoid accidentally pulling the cord during normal operation. Loss of engine power means the loss of most steering control. Also, without engine power, the boat could slow rapidly. This could cause people and objects in the boat to be thrown forward.**

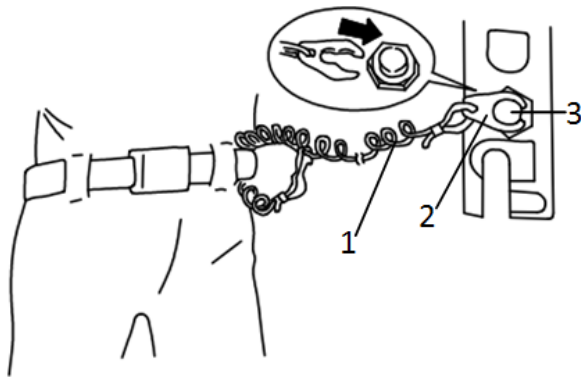

1. Cord.
2. Clip
3. Engine shut-off switch

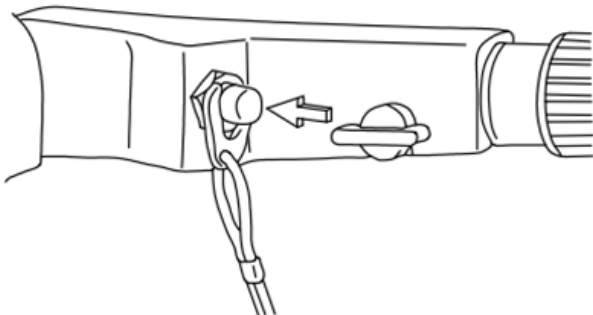

1. Cord.
2. Clip
3. Engine shut-off switch

## Engine stop button

The engine stop button stops the engine when the button is pushed.

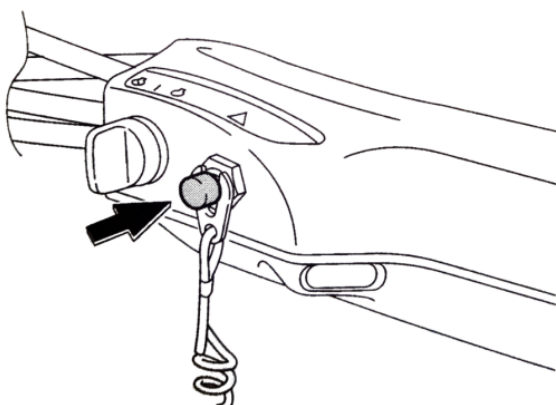

---

## Main switch

The main switch controls the ignition system; its operation is described below.

- **“OFF” (off)**

With the main switch in the **“OFF”**(off) position , The electrical circuits are off, and the key can be removed.

- **“ON” (on)**

With the main switch in the **“ON”**(on) position , The electrical circuits are on, and the key cannot be removed.

- **“START”**(start)

With the main switch in the **“START”**(start) position , The starter motor turns to start the engine. When the key is released, it returns automatically to the **“ON”**(on) position.

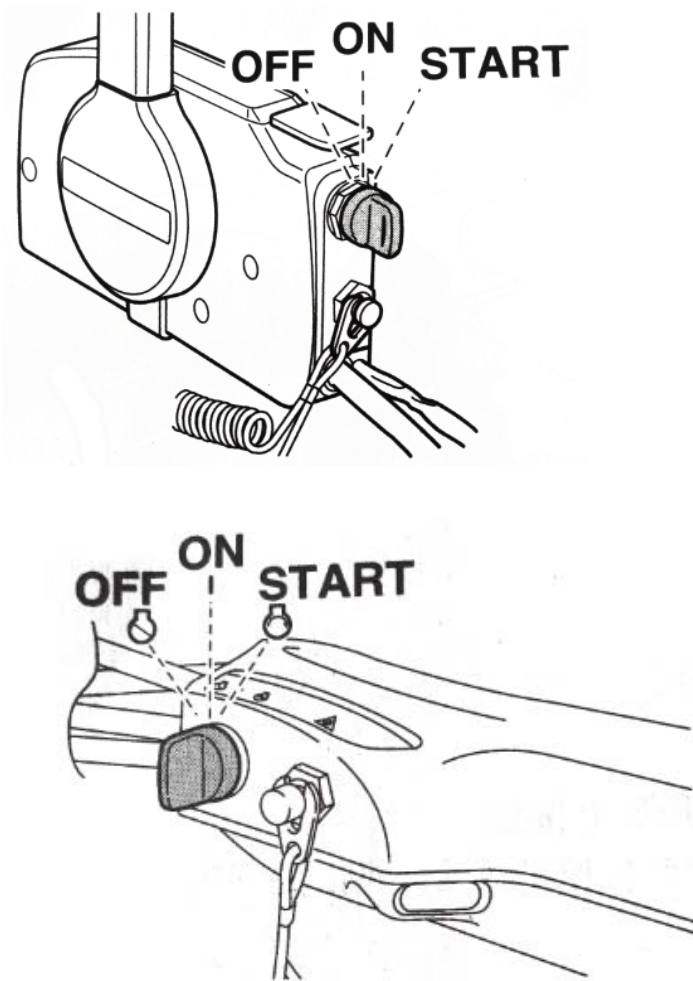

## Steering friction adjuster

A friction device provides adjustable resistance to the steering mechanism, and can be set

---

according to operator preference. An adjuster lever is located on the bottom of the tiller handle bracket.

To increase resistance, turn the lever to the port side “A”.

To decrease resistance, turn the lever to the starboard side “B”.

**⚠ WARNING**

**Do not over tighten the friction adjuster. If there is too much resistance, it could be difficult to steer, which could result in an accident.**

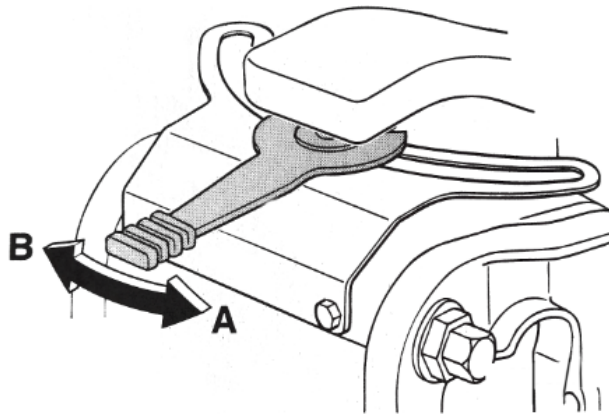

If the resistance does not increase even when the lever is turned to the port side “A”, make sure that the nut is tightened to the specified torque.

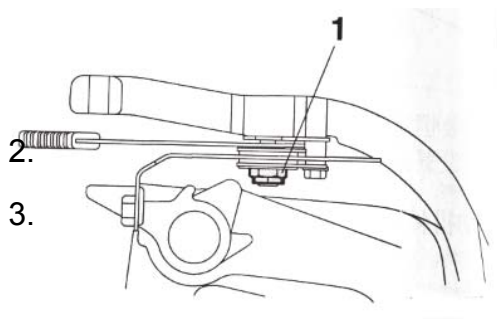

1. Nut

**Nut tightening torque:** 6 Nm (0.61 kgf -m, 4.4 ft-lb)

**TIP:**

- Steering movement is blocked when the adjuster lever is set to the “A” position.
- Check the tiller handle for smooth movement when the lever is turned to the starboard side “B”.
- Do not apply lubricants such as grease to the friction areas of the steering friction adjuster.

---

## Power trim and tilt switch on remote control or tiller handle

The power trim and tilt system adjusts the outboard motor angle in relation to the transom. Pressing the switch “UP” (up) trims like the outboard motor up, and then tilts it up, Pressing the switch “DN” (down) tilts the outboard motor down and trims it down. When the switch is released, the outboard motor will stop in its current position.

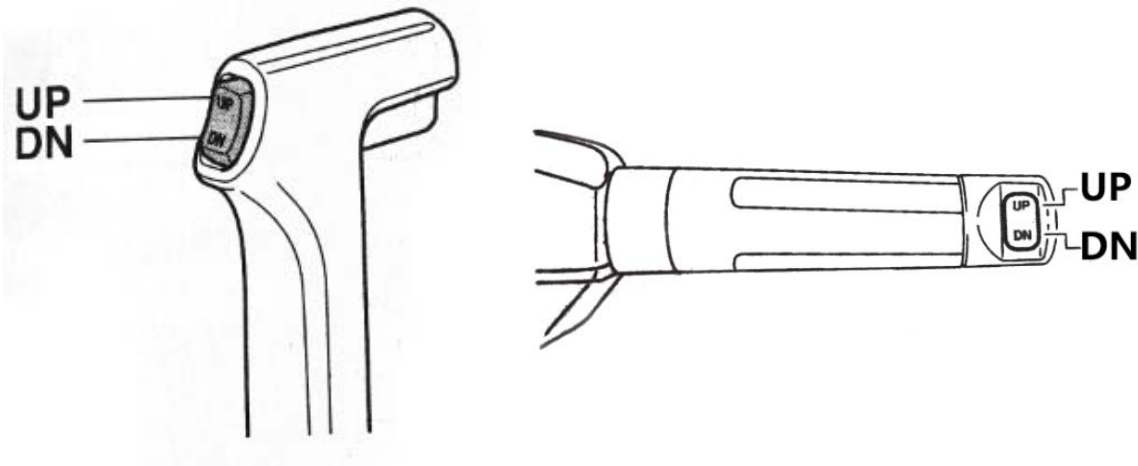

**⚠ WARNING** Use the power trim and tilt switch located on the bottom coving only when the boat is at a complete stop with the engine off. Attempting to use this switch while the boat is moving could increase the risk of falling overboard and could distract the operator, increase the risk of collision with another boat or an obstacle.

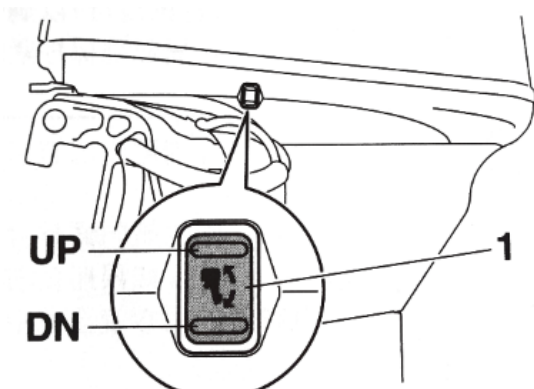

1. Power trim and tilt switch

## Trim with anode

**⚠ WARNING** An improperly adjusted trim tab could cause difficult steering. Always test run after the trim tab has been installed or replaced to be sure steering is

**correct. Be sure you have tightened the bolt after adjusting the trim tab.**

The trim tab should be adjusted so that the steering control can be turned to either the right or left by applying the same amount of force.

If the boat tends to veer to the left (port side), turn the trim tab end to the port side "A" in the figure. If the boat tends to veer to the right (starboard side), turn the trim tab end to the starboard side "B" in the figure.

**NOTICE:**

The trim tab also serves as an anode to protect the engine from electrochemical corrosion. Never paint the trim tab as it will become ineffective as an anode.

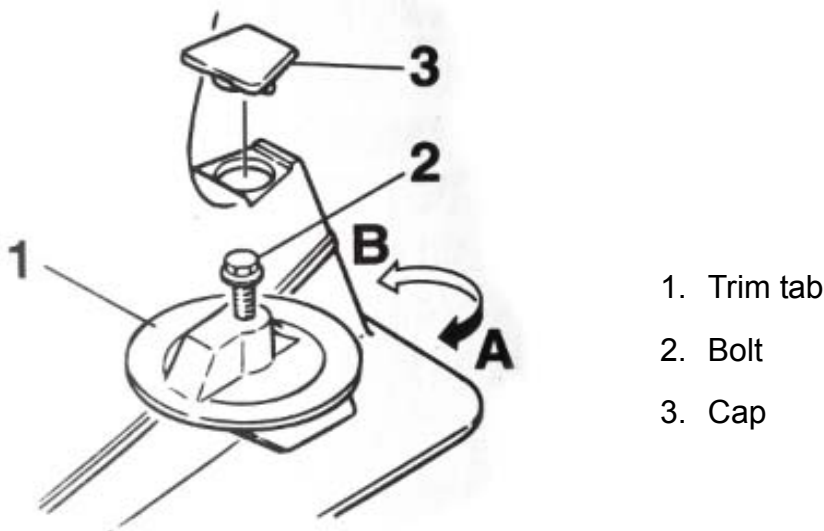
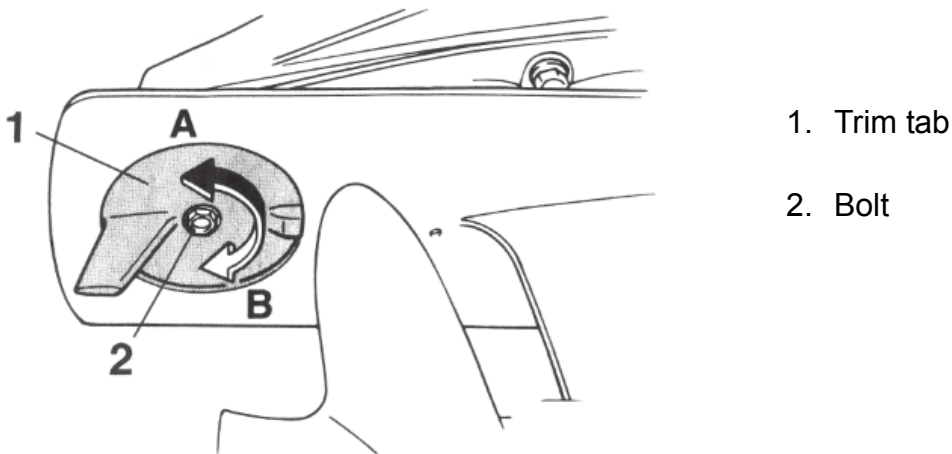

**Bolt tightening torque:**

18Nm (1.84 kgf-m, 13.3 ft-lb)

---

### Trim rod (tilt pin)

The position of the trim rod determines the minimum trim angle of the outboard motor in relation to the transom.

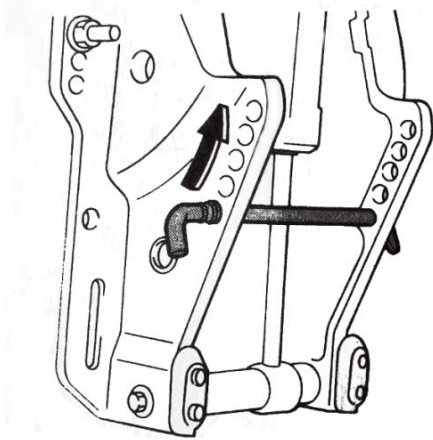



### Tilt lock mechanism

The tilt lock mechanism is used to prevent the outboard motor from lifting out of the water when in reverse gear.



1. Tilt lock lever

To lock it, set the tilt lock lever in the “” lock position. To release, push the tilt lock lever in the “” release position.

### Tilt support lever foe power trim and tilt or hydro tilt model

To keep the outboard motor in the tilted up position, lock the tilt support lever to the clamp bracket.

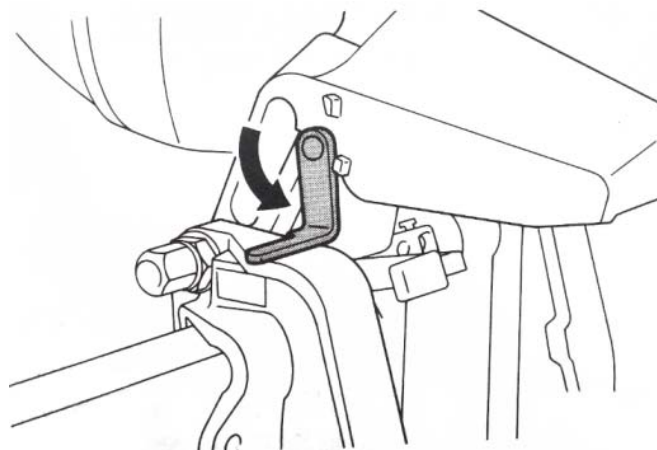

---

**NOTICE:**

Do not use the tilt support lever or knob when trailering the boat. The outboard motor could shake loose from the tilt support and fall. If the motor cannot be trailered in the normal running position, use an additional support device to secure it in the tilt position.

**Cowling lock lever**

The cowling lock levers are used to secure the top cowling.

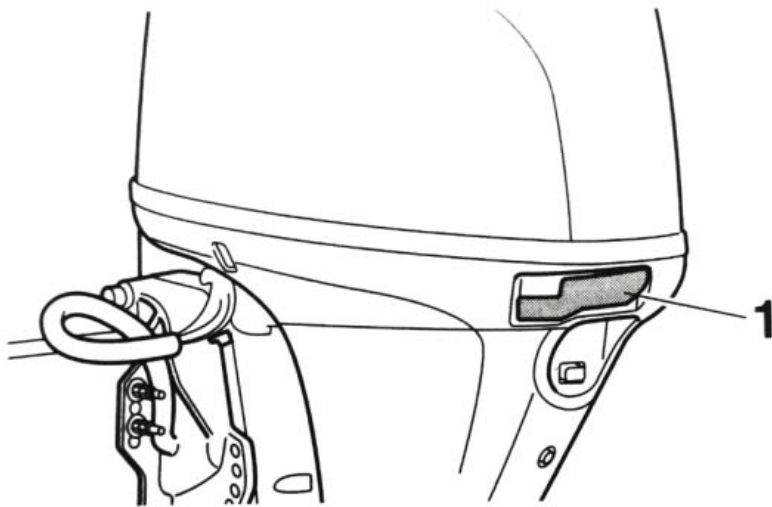

1. Cowling lock lever(s)

**Flushing device**

This device is used to clean the cooling water passages of the motor using a garden hose and tap water.

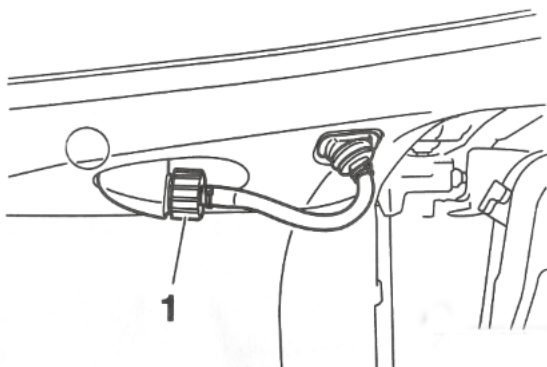

1. Flushing device

**Fuel filter/water separator**

This engine has a combination fuel filter/water separator and associated alert system. If water separated from the fuel exceeds a separator volume, the alert device will activate.



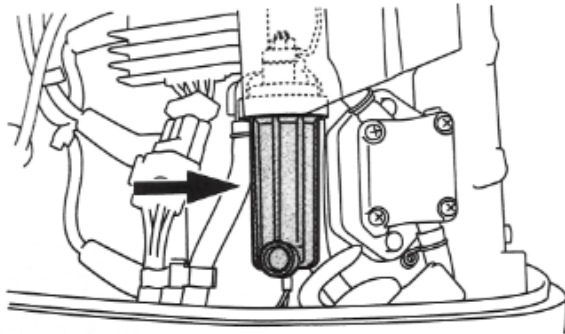
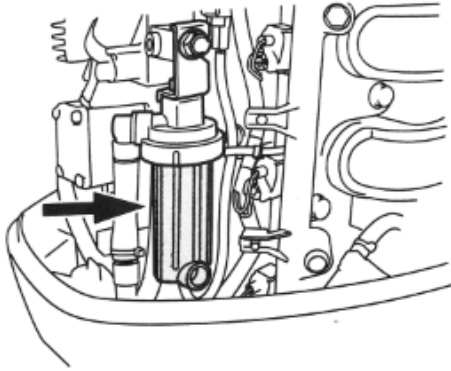

## Instruments and indicators

### Digital tachometer

The tachometer shows the engine speed and has the following functions.

All segments of the display will light momentarily after the main switch is turned on and will return to normal thereafter.

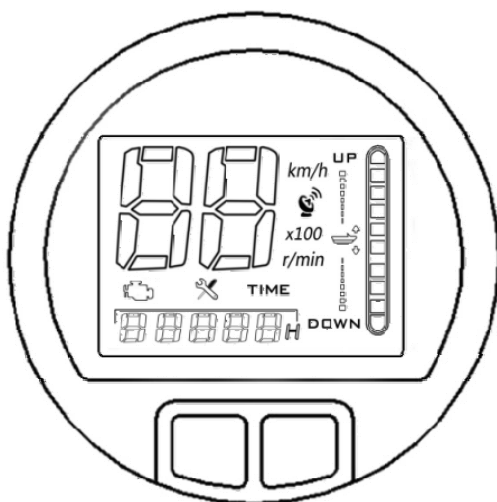

1. Tachometer
2. Trim meter
3. Hour meter
4. Low oil pressure-alert indicator
5. Overheat-alert indicator
6. Set button
7. Mode button

#### Tip:

The water separator and engine trouble-alert indicators only operate when the engine is equipped with the appropriate functions.

---

## Tachometer

The tachometer displays engine speed in hundreds of revolutions per minute (r/min). For example, if the tachometer display reads “22” then the engine speed is 2200 r/min.

## Trim meter

This meter shows the trim angle of your outboard motor.

- Memorize the trim angles that work best for your boat under different conditions. Adjust the trim the trim angle to the desired using the power trim and tilt switch.
- If the trim angle of your motor exceeds the trim operating range, the stop segment on the trim meter display will blink.

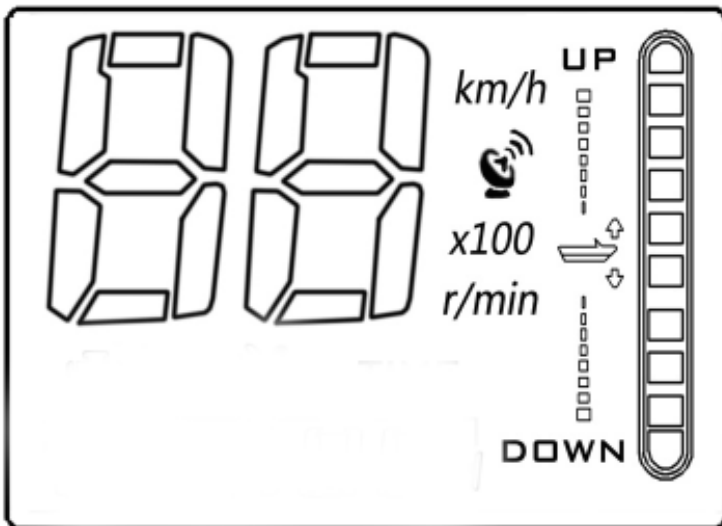

## Hour meter

This meter shows the number of hours the engine has been run.

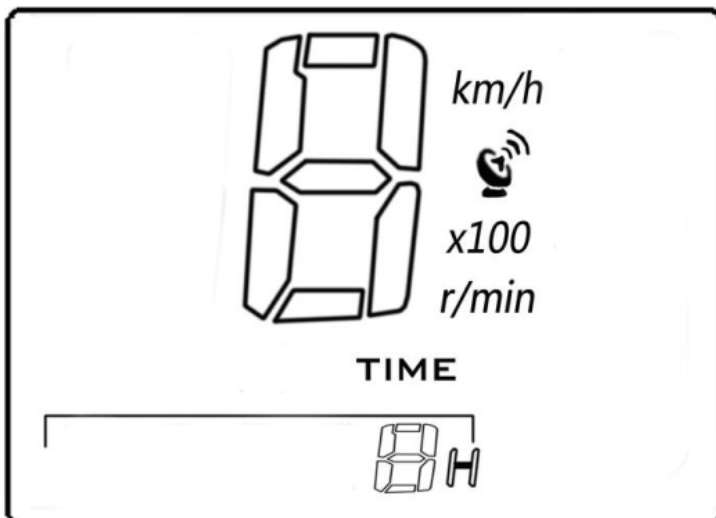

---

## Engine fault alarm

If the outboard motor fails, the alarm indicator will begin to flash.

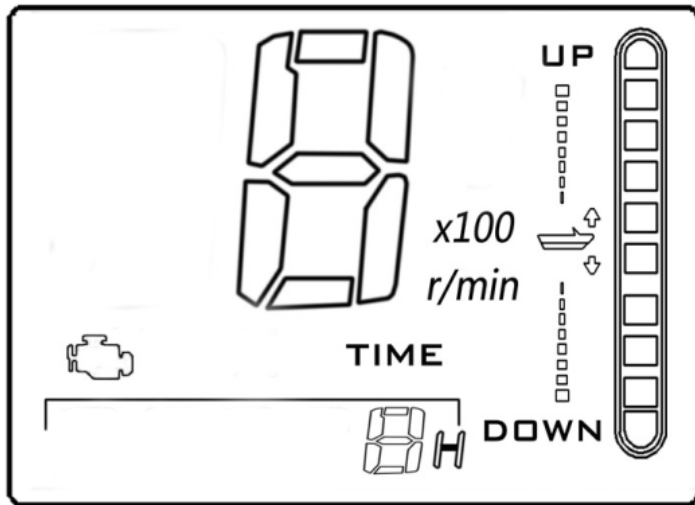

### **NOTICE**

**Do not continue to run the engine trouble alarm lights up. Serious engine damage will occur.**

### **Set up button**

Boot after the normal display, first to press 4 times button on the left side of the background lamp, then press 1 times on the right button, according to the background light button on the left side of the 5 times, finally press the right button 1 times, into the speed adjustment model, on the left side of the background light button for frequency values, button on the right side as the frequency values, adjustment is completed, stop the operation, save data automatically after 5 times seconds.

### **TIP:**

Perform the operation within 1 minute after starting up before entering the speed adjustment mode.

When the sensor is not connected, the tilting Angle frame flashes.

## **Engine control system**

### **Alert system**

### **NOTICE:**

**Do not continue to operate the engine if an alert device has activated. Consult your**

---

**dealer if the problem cannot be located and corrected.**

### **Overheat alert**

This engine speed has an overheat-alert device. If the temperature rises too high, the alert device will activate.

- The engine speed will automatically decrease to about 2000 r/min.
- The overheat-alert indicator will light or blink.
- The buzzer will sound (if equipped on the tiller handle, remote control box, or main switch panel).

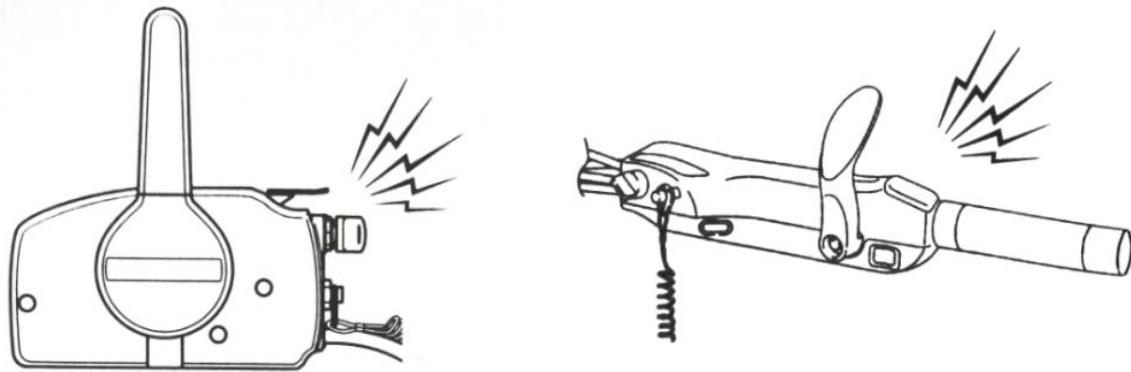

If the alert system has activated, stop the engine and check the cooling water inlets:

- Check trim angle to be sure that the cooling water inlet is submerged.
- Check the cooling water inlet for clogging.



### **Low oil pressure alert**

If the oil pressure drops too low, the alert device will activate.

- The engine speed will automatically decrease to about 2000 r/min. If equipped with a low oil pressure-alert indicator, it will light or blink.

- 
- The buzzer will sound (if equipped on the tiller handle, remote control box, or main switch panel).

If the alert system has activated, stop the engine as soon as it is safe to do so. Check the oil level and add oil as needed. If the oil level is correct and the alert device dose not switches off, consult your dealer.

## Installation

### Installation

The information presented in this section is intended as reference only. It is not possible to provide complete instructions for every possible boat and motor combination. Proper mounting depends in part on experience and the specific boat and motor combination.



**Overpowering a boat could cause severe instability. Do not install an outboard motor with more horsepower than the maximum rating on the capacity plate of the boat .If the boat does not have a capacity plate, consult the boat manufacturer.**

**Improper mounting of the outboard motor could result in hazardous conditions such as poor handle, loss of control, or fire hazards. For permanently mounted models, your dealer or other person experienced in proper rigging should mount the motor.**

### Mounting the outboard motor

The outboard motor should be mounted so that the boat is well balanced. Otherwise, the boat could be hard to steer. For single-engine boats, mount the outboard motor on the centerline (keel line) of the boat.

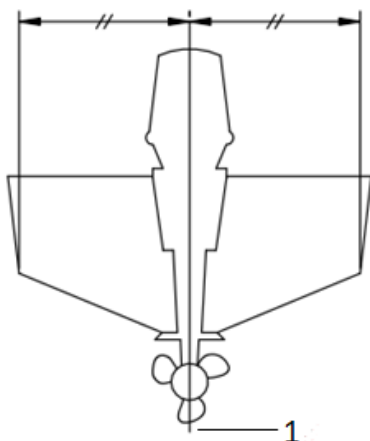

1. Center line (keel line)

---

## Mounting height (boat bottom)

The mounting height of your outboard motor affects its efficiency and reliability. If it is mounted too high, propeller ventilation may occur, which will reduce propulsion due to excessive propeller slip. And the water intakes for the cooling system may not get an adequate water supply, which can cause engine overheating. If the engine is mounted too low, water resistance (drag) will increase, thereby reducing engine efficiency and performance.

Most commonly, outboard motor should be mounted so that the anti-cavitation plate is in alignment with the bottom of the boat. The optimum mounting height of the outboard motor is affected by the boat/motor combination and the desired use. Test runs at different heights can help determine the optimum mounting height. Consult your dealer or boat manufacturer for further information on determining the proper mounting height.

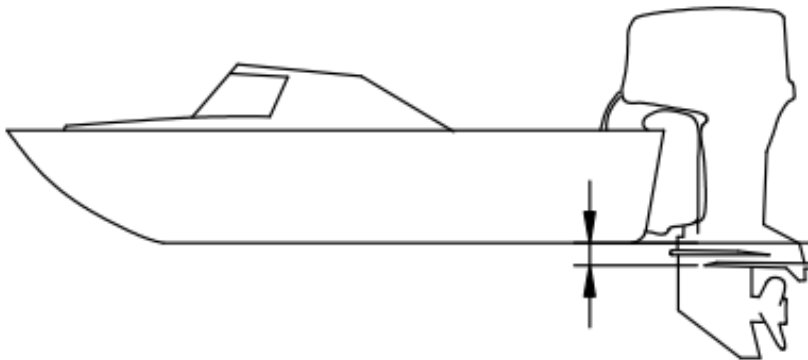

### **NOTICE:**

- **Make sure that the idle hole is high enough to prevent water from entering the engine even if the boat is stationary with the maximum load.**
- **Incorrect engine height or obstructions to the smooth flow of water (such as the design or condition of the boat, or accessories, such as transom ladders or depth finder transducers) can create airborne water spray while the boat is cruising. If the outboard motor is operated continuously in the presence of airborne water spray, enough water could enter the engine through the air intake opening in the top cowling to cause severe engine damage. Remove the cause of the airborne water spray.**

---

## Operation

### First-time operation

#### Fill engine oil

The engine is shipped from the factory without engine oil. If your dealer did not fill the oil, you must fill it before starting the engine. **NOTICE: Check that the engine is filled with oil before first-time operation to avoid severe engine damage.**

The engine is shipped with the following tag, which should be removed after engine oil is filled for the first time. For more information on checking the engine oil level.



#### Breaking in engine

Your new engine requires a period of break-in to allow mating surfaces of moving parts to wear in evenly. Correct break-in will help ensure proper performance and longer engine life.

**NOTICE: Failure to follow the break-in procedure could result in reduced engine life or even severe engine damage.**

#### Procedure for 4-stroke models

Your new engine requires a period of 10 hours break-in to allow mating surfaces of moving parts to wear in evenly.

#### TIP:

Run the engine in the water, under load (in gear with a propeller installed) as follows. For 10 hours for breaking in engine avoid extended idling, rough water and crowded areas.

1. For the first hour of operation:

Run the engine at varying speeds up to 2000 r/min or approximately half throttle.

---

2. For the second hour of operation:

Increase engine speed as much as necessary to put the boat on plane (but avoid full-throttle operation). Then back off on the throttle while keeping the boat at a planning speed.

3. Remaining 8 hours:

Run the engine at any speed. However, avoid operating at full throttle for more than 5 minutes at a time.

4. After the first 10 hours:

Operate the engine normally.

### **Getting to know your boat**

All boats have unique handling characteristics. Operate cautiously while you learn how your boat handles under different conditions and various trim angles.

## **Check before starting engine**

**⚠ WARNING** If any item in “Check before starting engine” is not working properly, have it inspected and repaired before operating the outboard motor.

Otherwise, an accident could occur.

**NOTICE:** Do not start the engine out of water. Overheating and serious engine damage can occur.

### **Fuel level**

Be sure you have plenty of fuel for your trip. A good rule is to use 1/3 of your fuel to get to the destination. 1/3 to return, and to keep 1/3 as an emergency reserve. With the boat level on a trailer or in the water, turn the key to “ON”(on) and check the fuel level.

### **Remove the top cowling**

For the following checks, remove the top cowling from the bottom cowling. To remove the top cowling, release the cowling lock lever and lift off the top cowling.

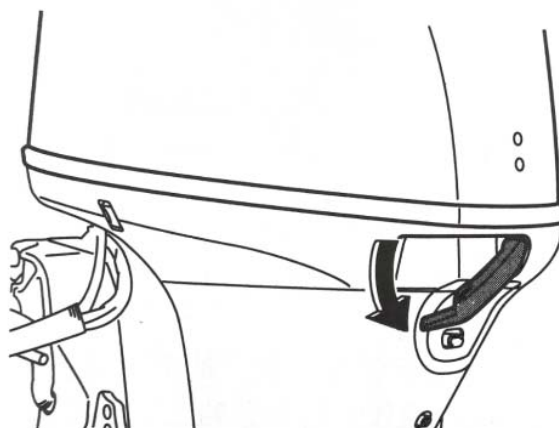



---

## Fuel system



Gasoline and its vapors are highly flammable and explosive.

Keep away from sparks, cigarettes, flames, or other sources of ignition.



Leaking fuel can result in fire or explosion.

- Check for fuel leakage regularly.
- If any fuel leakage is found, the fuel system must be repaired by a qualified mechanic. Improper repairs can make the outboard unsafe to operate.

## Check for fuel leaks

- Check for fuel leaks or gasoline fumes in the boat.
- Check for fuel leakage from the fuel system.
- Check for fuel tank and fuel lines for crack, swellings, or other damages.

## Checking the fuel filter

Check that the fuel filter is clean and free of water. If any water is found in the fuel, or if a significant amount of debris is found, the fuel tank should be checked and cleaned by a dealer.

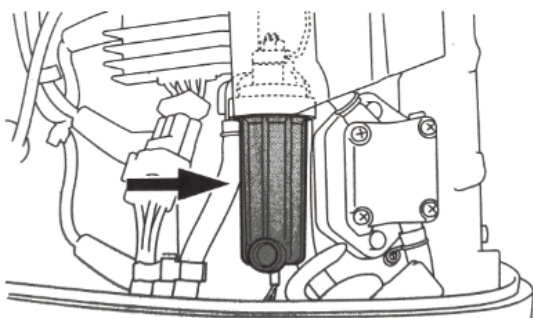
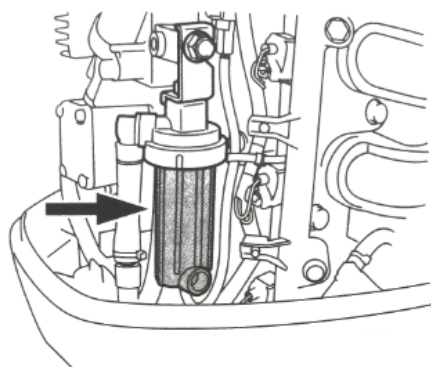

---

## Control

Tiller handle models:

- Move the tiller handle fully to the left and right to make sure operation is smooth.
- Turn the throttle grip from the fully closed to the fully open position. Make sure that it turns smoothly and that it completely returns to the fully closed position.
- Look for loose or damaged connections of the throttle and shift cabbies.

Remote control models:

- Turn the steering wheel full-right and full-left. Make sure operation is smooth and unrestricted throughout the whole range with no binding or excessive free play.
- Operate the throttle levers several times to make sure there is no hesitation in their travel. Operation should be smooth over the complete range of motion, and each lever should return completely to the idle position.
- Look for loose or damaged connections of the throttle and shift cables.

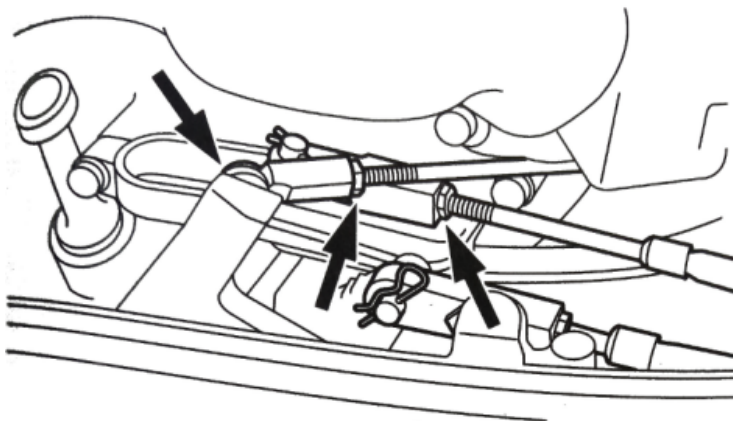

## Engine shut-off cord (lanyard)

Inspect the engine shut-off cord and clip for damage, such as cuts, breaks, and water.

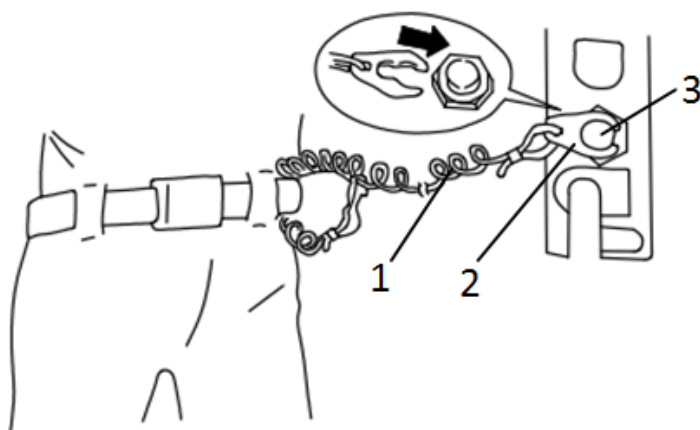

1. Cord
2. Clip
3. Engine shut-off switch

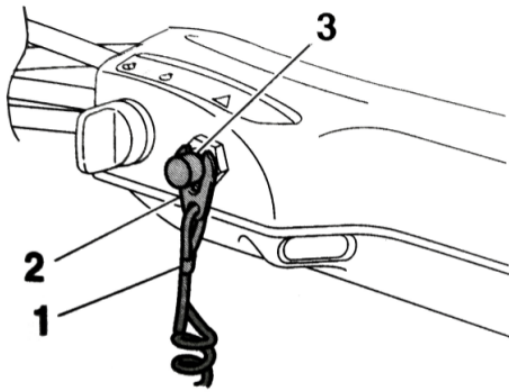

1. Cord
2. Clip
3. Engine shut-off switch

## Engine oil

1. Place the outboard motor in a vertical position (not tilted). **NOTICE: If the outboard motor is not level, the oil level indicated on the oil dipstick may not be accurate.**
2. Remove the oil dipstick and wipe it clean.

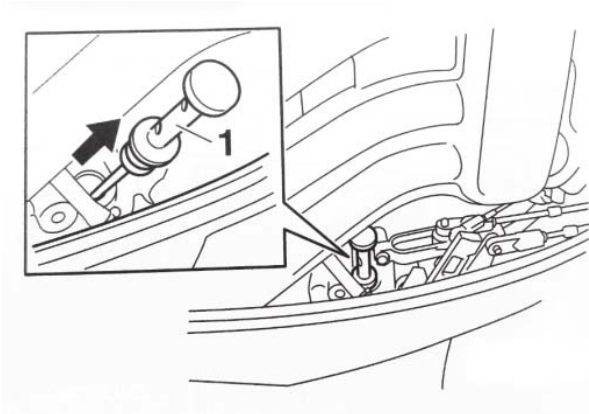

1. Oil dipstick

3. Insert the oil dipstick completely and remove it again.
4. Check that the oil level on the oil dipstick is between the upper and lower marks. Consult your dealer if the oil level is not at the proper level or if it appears milky or dirty.

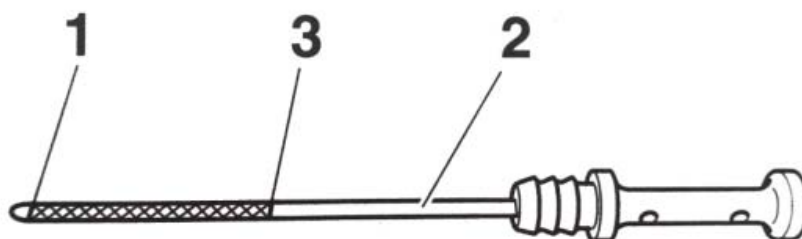

1. Lower mark
2. Oil dipstick
3. Upper mark

## Engine

- Check the engine and engine mounting.
- Look for loose or damage fasteners.
- Check the propeller for damage.
- Check for engine oil leaks.

---

## Flushing device

Check that the flushing device's garden hose connector is securely screwed on to the fitting on the bottom cowling. **NOTICE: If the garden hose connector is not properly connected, cooling water can leak out and the engine can overheat during operation.**

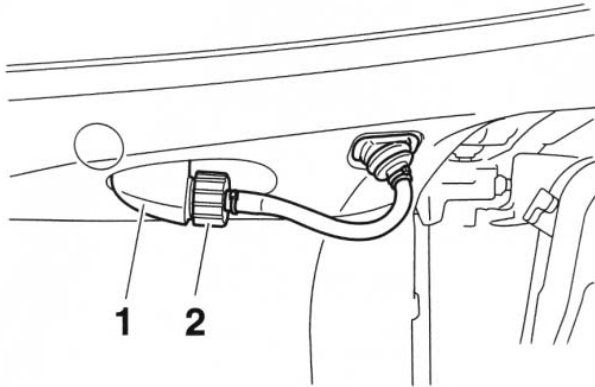

1. Fitting
2. Flushing device

## Install top cowling

1. Be sure that the cowling lock lever is released.
2. Be sure that the rubber seal is seated all the way around the top cowling.
3. Place the top cowling on the bottom cowling.
4. Check to be sure the rubber seal is seated correctly between the top cowling and the bottom cowling.
5. Move the cowling lock lever to lock the top cowling as shown. **NOTICE: If the top cowling is not installed correctly, water spray under the top cowling can damage the engine, or the top cowling can blow off at high speeds.**

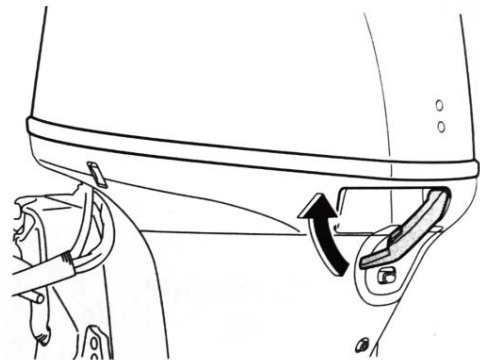

After installing, check the fitting of the top cowling by pushing it with both hands. If the top cowling is loose, have it repaired by your dealer.



---

## Power trim and tilt system

### **WARNING**

- Never get under the lower unit while it is tilted, even when the tilt support lever is locked. Severe injury could occur if the outboard motor accidentally falls.
  - Body parts can be crushed between the motor and the clamp bracket when the motor is trimmed or tilted.
  - Be sure no one is near the outboard motor before performing this check.
1. Check the power trim and tilt unit for any sign of oil leaks.
  2. Operate each of the power trim and tilt switches to check that all switches work.
  3. Tilt the outboard motor up and check that the trim and tilt rod is pushed out completely.

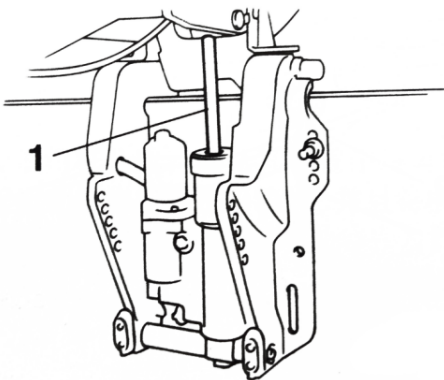

1. Trim and tilt rod.

4. Check that the trim and tilt is free of corrosion or other flaws.
5. Tilt the outboard motor down. Check that the trim and tilt rod operates smoothly.

## Battery

Check that the battery's charge. If your boat is equipped with a digital speedometer, the voltmeter and low battery alert functions will help you monitor the battery's charge. A battery in good condition will provide a minimum of 12 volts. Check that the battery connections are clean, secure and covered by insulating covers. The electrical contacts of the battery and cables must be clean and properly connected or battery will not start the engine.

If the battery needs charging, consult your dealer or the battery manufacturer's instructions.

---

## Filling fuel

### WARNING

- Gasoline and its vapors are highly flammable and explosive. Always refuel according to this procedure to reduce the risk of fire and explosion.
  - Gasoline is poisonous and can cause injury or death. Handle gasoline with care. Never siphon gasoline by mouth. If you should swallow some gasoline or inhale a lot of gasoline vapor, or get some gasoline in your eyes, see your doctor immediately. If gasoline spills on your skin, wash with soap and water. If gasoline spills on your clothing, change your clothes.
1. Be sure the engine is stopped.
  2. Disconnect the fuel line from the fuel tank and tighten the air vent screw on the fuel tank cap.

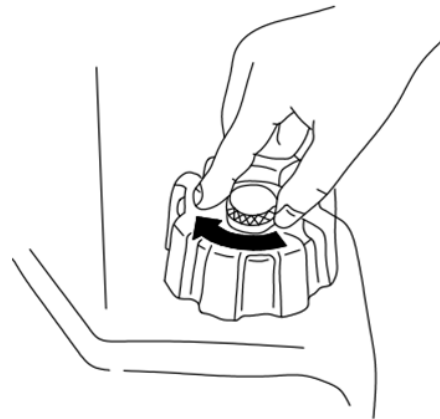
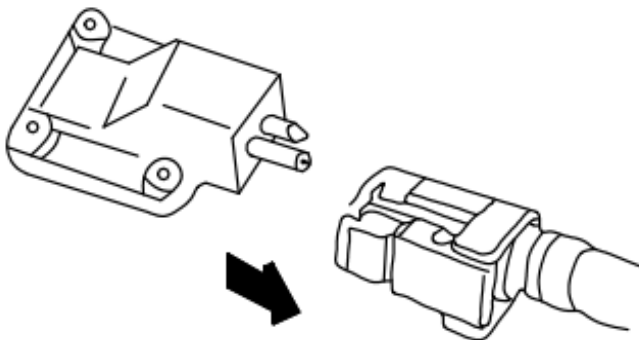

3. Remove the fuel tank from the boat.
4. Fill the fuel tank with fuel, but do not overfill.
5. To loosen the air vent screw, turn it counterclockwise until it stops.
6. While pressing and holding the pressure relief tab under the fuel tank cap again, turn the fuel tank cap, slowly turn the fuel tank cap counterclockwise 1/4 turn.
7. While pressing and holding the pressure relief tab under the fuel tank cap again, turn the fuel tank cap counterclockwise to remove it.
8. Do not smoke and keep away from sparks, flames, static electric discharge, or other

---

sources of ignition.

Fill the fuel tank, but do not overfill. **WARNING!** Do not overfill. Otherwise fuel can expand and overflow if the temperature increases.

Fuel tank capacity:

24 L (6.34 US gal, 5.28 Imp. gal)

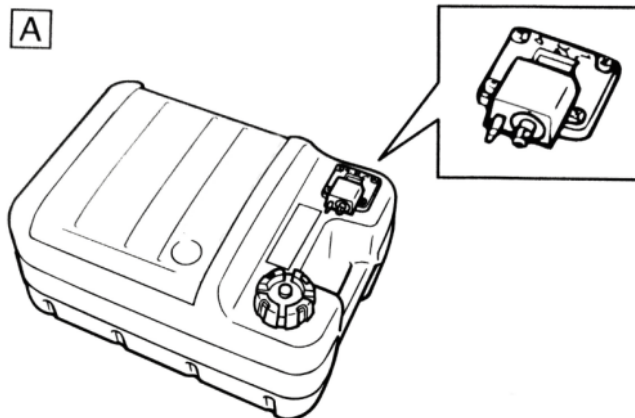

9. Turn the fuel tank cap clockwise to tighten until a click is heard.

10. Turn the air vent screw clockwise to close it.

## Operating engine

### **WARNING**

- Before starting the engine, make sure that the boat is tightly moored and that you can steer clear of any obstructions. Be sure there are no swimmers in the water near you.
- When the air vent screw is loosened, gasoline vapor will be released. Gasoline is highly flammable, and its vapors are flammable and explosive. Refrain from smoking, and keep away from open the air vent screw.
- This product emits exhaust gases which contain carbon monoxide, a colorless, odorless gas which could cause brain damage or death when inhaled. Symptoms include nausea, dizziness, and drowsiness. Keep cockpit and cabin areas well ventilated. Avoid blocking exhaust outlets.

---

## **Sending fuel (portable tank)**

When using the portable fuel tank "A", send fuel to the outboard motor according to the following procedure.

1. If there is a vent screw on the tank cap, loosen it 2 or 3 turns.



2. If there is a fuel joint in the motor, align the fuel joint on the fuel line with the fuel joint on the motor and firmly connect the fuel line to the joint while pinching the joint. Then firmly connect the other end of the fuel line to the joint on the fuel tank.

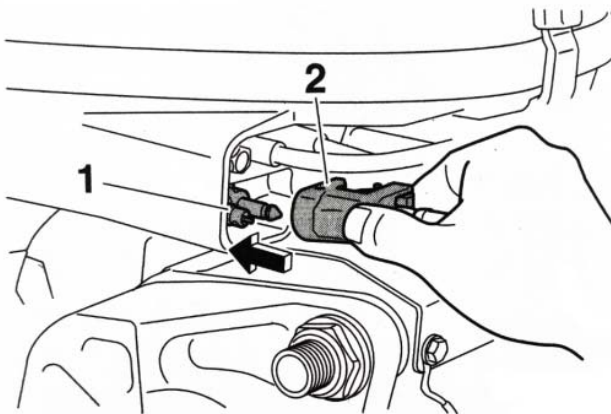

1. Fuel joint
2. Fuel hose

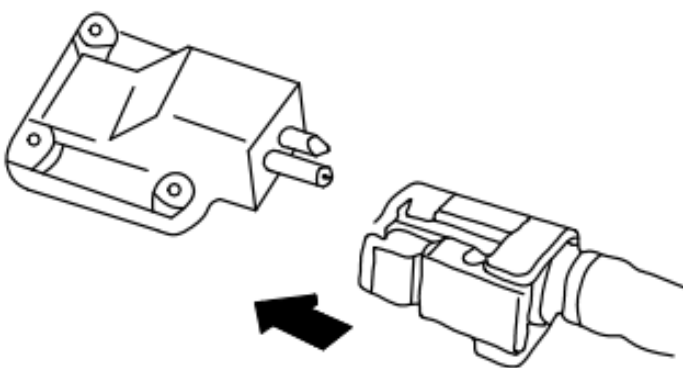



---

**Tip:**

Wipe up any spilled gasoline immediately with dry rags. Dispose rags properly according to local laws or regulations.

3. Squeeze the primer pump, with the arrow pointing up, until you feel it become firm. During engine operation place the tank horizontally, otherwise fuel cannot be drawn from the fuel tank.

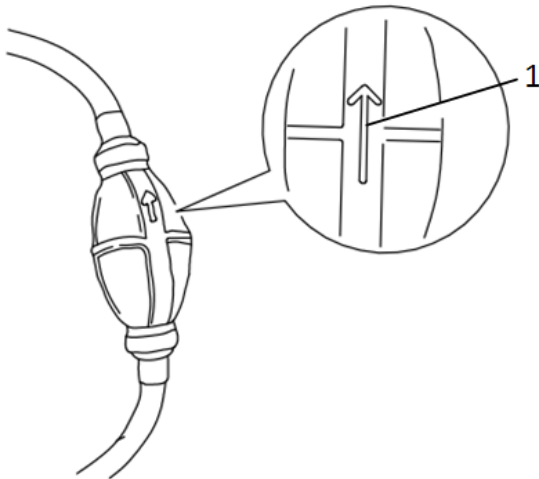

1. Arrow

**Starting engine**

**⚠ WARNING** Before starting the engine, make sure that the boat is tightly moored and that you can steer clear of any obstructions. Be sure there are no swimmers in the water near you.

**Electric start/prime start models**

**⚠ WARNING**

- Failure to attach the engine shut-off cord could result in a runaway boat if operator is ejected. Attach the engine shut-off cord to a secure place on your clothing, or your arm or leg while operating. Do not attach the cord to clothing that could tear loose. Do not route the cord where it could become entangled, preventing it from functioning.
- Avoid accidentally pulling the cord during normal operation. Lose of engine power means the loss of most steering control. Also, without engine power, the boat could slow rapidly. This could cause people and objects in the boat to be thrown forward.

---

## Electric start and remote control models

### **WARNING**

- Failure to attach the engine shut-off cord could result in a runaway boat if operator is ejected. Attach the engine shut-off cord to a secure place on your clothing, or your arm or leg while operating. Do not attach the cord to clothing that could tear loose. Do not route the cord where it could become entangled, preventing it from functioning.
- Avoid accidentally pulling the cord during normal operation. Loss of engine power means the loss of most steering the boat could slow rapidly. This could cause people and objects in the boat to be thrown forward.

1. Place the gear shift lever in neutral.

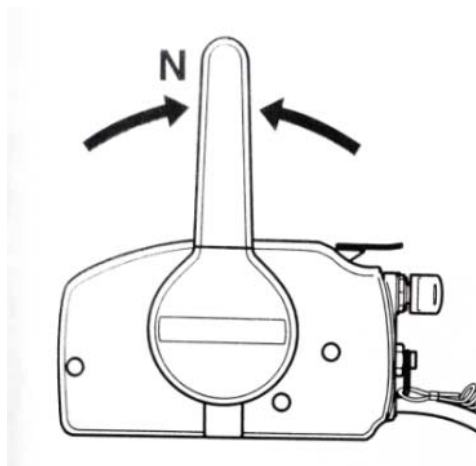

#### **TIP:**

The start-in-gear protection device prevents the engine from starting except when in neutral.

2. Attach the engine shut-off cord to a secure place on your clothing, or your arm or leg. Then install the clip on the other end of the cord into the engine shut-off switch.

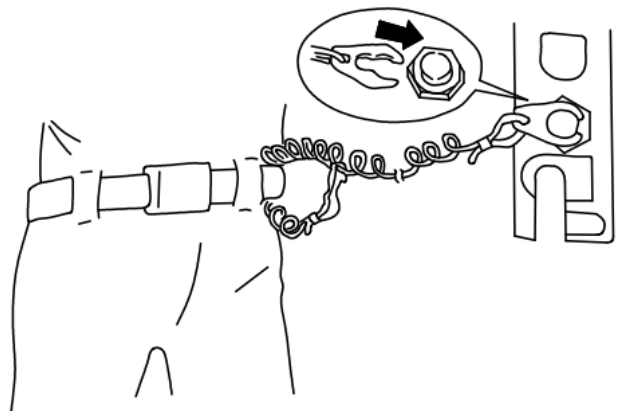

---

3. Turn the main switch to “ON”(on).

4. Turn the main switch to “START”(start), and held it for a maximum of 5 seconds

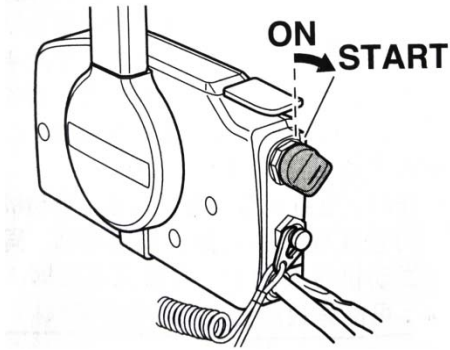

5. Immediately after engine starts, release the main switch and allow it to return to “ON” (on). **NOTICE:** Never turn the main switch to “START”(start) while the engine is running. Do not keep the starter motor turning for more than 5 seconds, If the starter motor is turned continuously for more than 5 seconds, the battery will be quickly discharged, thus making it impossible to start the engine. The starter can also be damaged. If the engine will not start after 5 seconds of cranking, return the main switch to “ON”(on), wait 10 seconds, then crank the engine again.

**TIP:**

- When the engine is cold, it needs to be warmed up.
- If the engine is warm and fails to start, open the throttle slightly and try to start the engine again. If the engine still fails to start.

### **Check after starting engine**

#### **Cooling water**

Check for a steady flow of water from the cooling water pilot hole. A continuous flow of water from the pilot hole indicates that the water pump is pumping water through the cooling water passages. If the cooling water passages are frozen, it may take a while for water to start flowing out of the pilot hole.

**NOTICE:** If water is not flowing out of the pilot hole at all times while the engine is running, overheating and serious damage could occur. Stop the engine and check whether the cooling water inlet on the lower case or the cooling water pilot hole is blocked. Consult your dealer if the problem cannot be located and corrected.

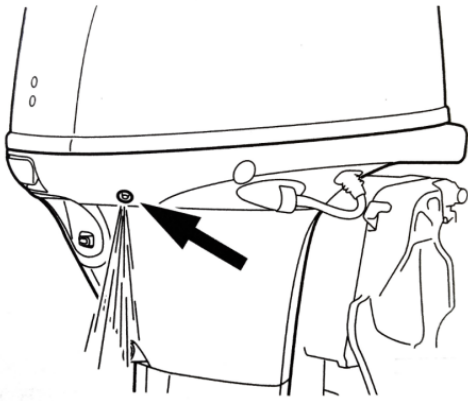

## Warming up engine

### Manual start and electric start model

1. After starting the engine, allow it to idle for 3 minutes to warm up. **NOTICE: Failure to do so will shorten engine life.**

2. Be sure the low oil pressure-alert indicator goes off after starting the engine.

**NOTICE: If the low oil pressure-alert indicator blinks after the engine starts, stop the engine. Otherwise, serious engine damage could occur. Check the oil level and add engine oil if necessary. Consult your dealer if the cause for the low oil pressure alert cannot be found.**

## Check after engine warm up

### Shifting

While the boat is tightly moored, and without applying throttle, confirm that the engine shifts smoothly into forward and reverse, and back to neutral.

### Stop switches

- Turn the main switch to “**OFF**”, or press the engine stop button and make sure the engine stops.
- Confirm that removing the clip from the engine shut-off switch stops the engine.
- Confirm that the engine cannot be started with the clip removed from the engine shut-off switch.

## Shifting

### **WARNING**

Before shifting, make sure there are no swimmers or obstacles in the water near you.

**NOTICE:** Warm up the engine before shifting into gear. Until the engine is warm, the idle speed may be higher than normal. High idle speed can prevent you from shifting back to neutral. If this occurs, stop the engine, shift to neutral, then restart the engine and allow it to warm up.

To shift out of neutral

1. Pull the neutral interlock trigger up (if equipped).

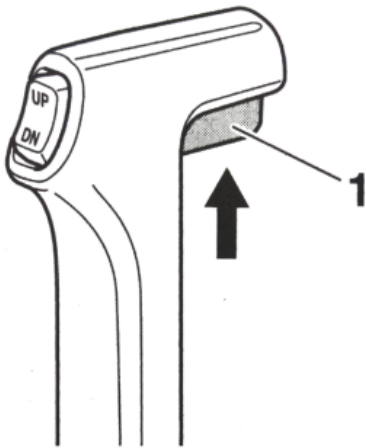

1. Neutral interlock trigger

2. Move the remote control lever/gear shift lever firmly and crisply forward (for forward gear) or backward (for reverse gear) [about 32° (a detent can be felt) for remote control models]. Be sure to check that the tilt lock lever is in the lock/down position (if equipped) before operating in reverse.

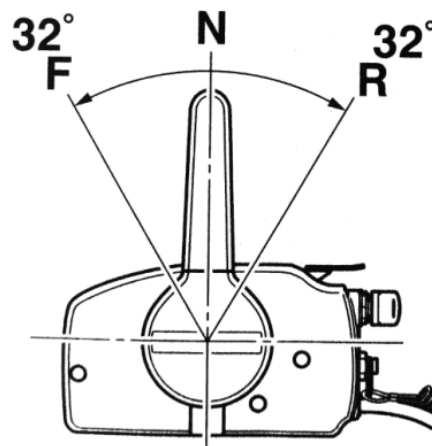
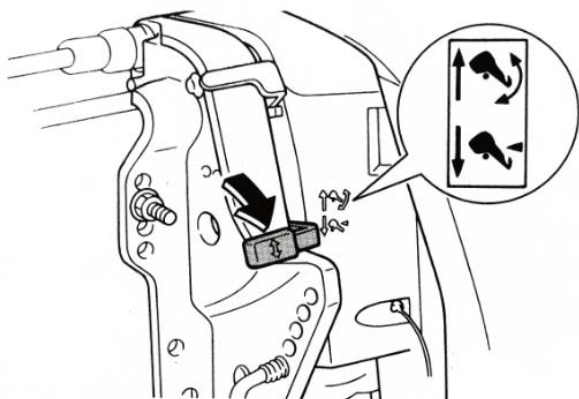

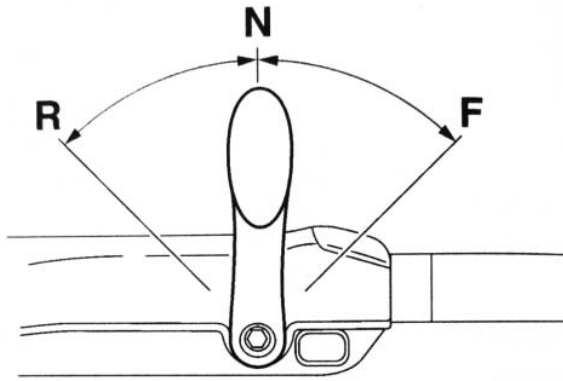

To shift from in gear (forward/reverse) to neutral.

1. Close the throttle so that the engine slows to idle speed.

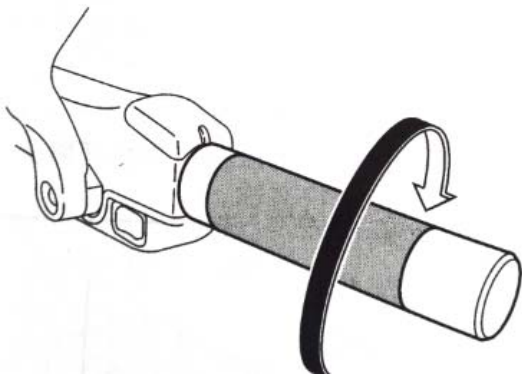
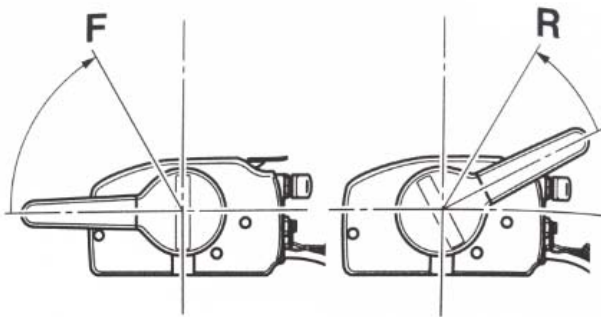

2. After the engine is at idle speed in gear move the remote control lever/gear shift lever firmly and crisply into the neutral position.

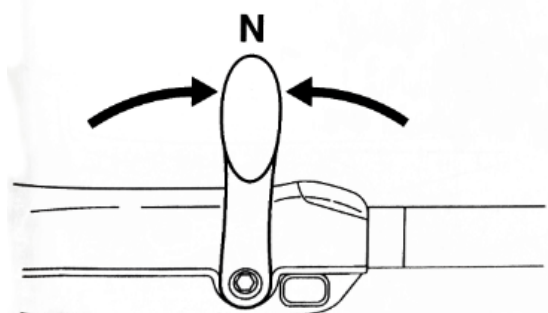
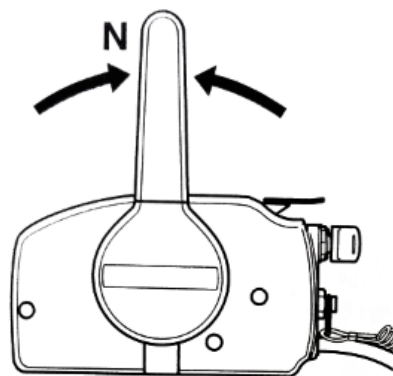

---

## Stopping boat

### **WARNING**

- Do not use the reverse function to slow down or stop the boat as it could cause you to lose control, be ejected, or impact the steering wheel or other parts of the boat. This could increase the risk of serious injury. It could also damage the shift mechanism.
- Do not shift into reverse while traveling at planning speeds. Loss of control, boat swamping, or damage to the boat could occur.

The boat is not equipped with a separate braking system. Water resistance stop it after the throttle lever is moved back to idle. The stopping distance varies depending on gross weight, water surface conditions, and wind direction.

## Stopping engine

Before stopping the engine, first let it cool off for a few minutes at idle or low speed. Stopping the engine immediately after operating at high speed is not recommended.

### Procedure

When using the portable fuel tank "A", stop the engine according to the procedure.

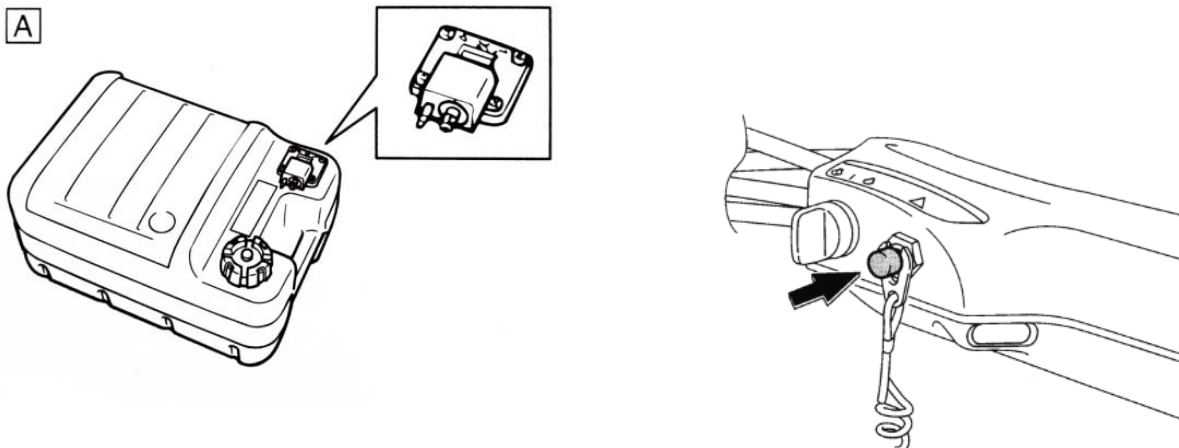

1. Push and hold the engine stop button or turn the main switch to "OFF"(off).

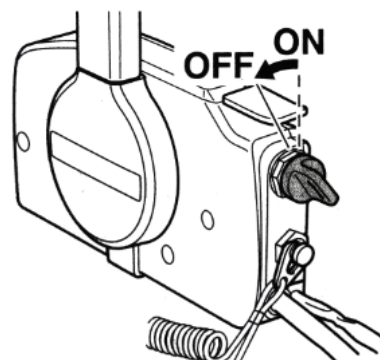

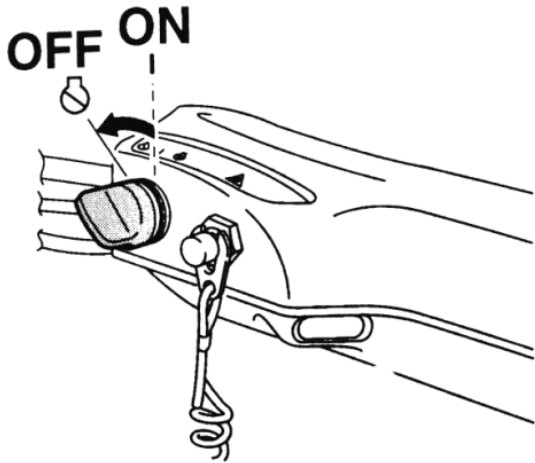

2. After stopping the engine, disconnect the fuel hose.

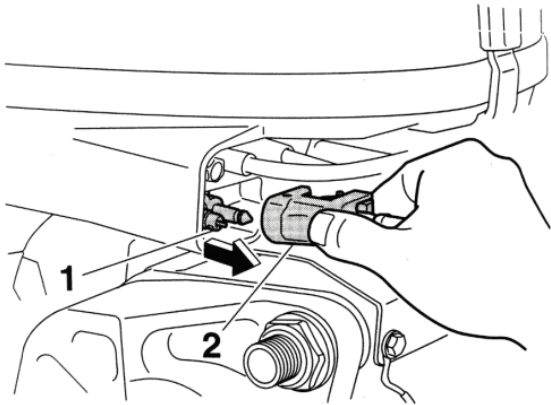

3. Tighten the air vent screw on the fuel tank cap.

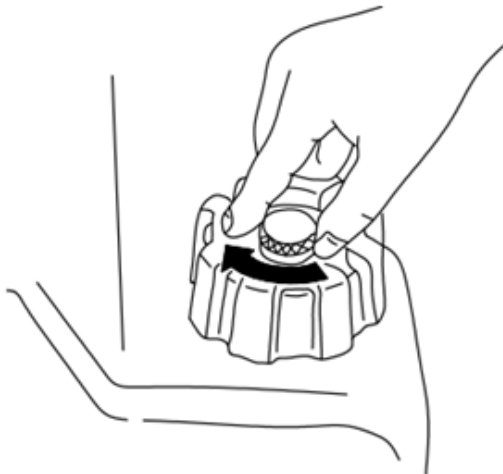

4. Remove the key if the boat will be left unattended.

**TIP:**

The engine can also be stopped by pulling the cord and removing the clip from the engine shut-off switch, then turning the main switch to "OFF"(off).



---

## Trimming outboard motor

### **⚠ WARNING**

Excessive trim for the operating conditions (either trim up or trim down) can cause boat instability and can make steering the boat more difficult. This increases the possibility of an accident. If the boat begins to feel unstable or is hard to steer, slow down and/or readjust the trim angle.

The trim angle of the outboard motor helps determine the position of the bow of the boat in the water. Correct trim angle will help improve performance and fuel economy while reducing strain on the engine. Correct trim angle depends upon the combination of boat, engine, and propeller. Correct trim is also affected by variables such as the load in the boat, sea conditions, and running speeds.

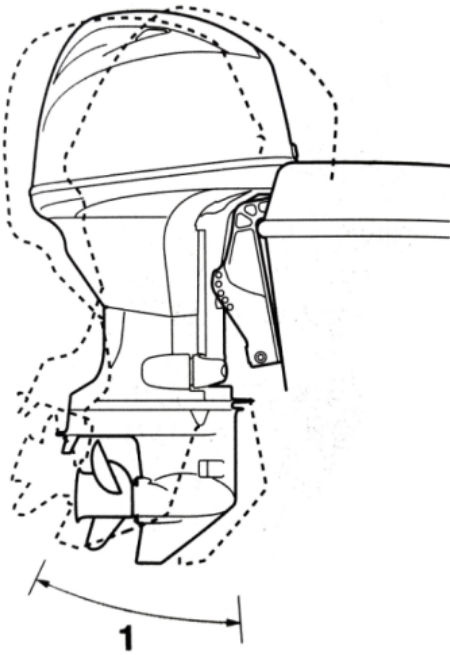

1. Trim operating angle

### Adjusting trim angle (Power trim and tilt)

### **⚠ WARNING**

- Be sure all people are clear of the outboard motor when adjusting the trim angle. Body parts can be crushed between the motor and the clamp bracket when the motor is trimmed or tilted.
- Use caution when trying a trim position for the first time, increase speed gradually and watch for any signs of instability or control problems. Improper trim angle can cause loss of control.

- 
- If equipped with a power trim and tilt switch located on the bottom cowling. Use the switch only when the boat is at a complete stop with the engine off. Do not adjust the trim angle with this switch the boat is moving.

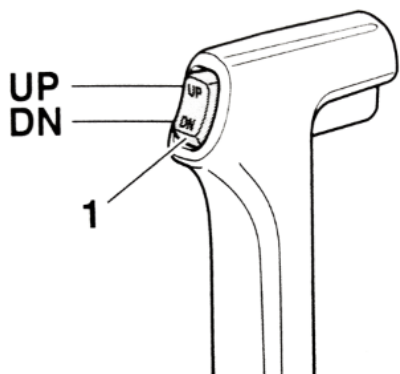

1. Power trim and tilt switch.

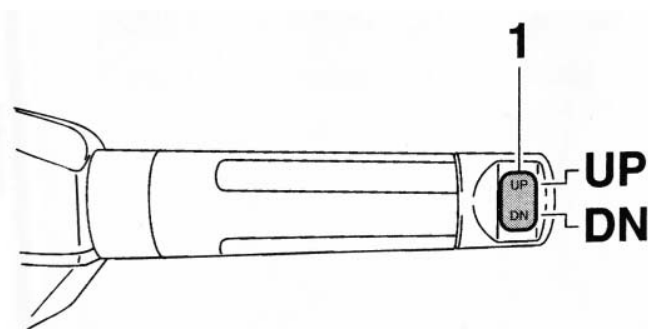

1. Power trim and tilt switch.

To raise the bow (trim-out), press the switch “UP” (up).

To lower the bow (trim-in), press the switch “DN” (down).

Make test runs the set to different angle to find the position that works best for your boat and operating conditions.

### Adjusting trim angle for hydro tilt models

#### **WARNING**

- Stop the engine before adjusting the trim angle.
  - Be sure all people are clear of the outboard motor when adjusting the trim angle, also be careful not to pinch any body parts between the drive unit and clamp bracket.
  - Use caution when trying a trim position for the first time. Increase speed gradually and watch for any signs of instability or control problems. Improper trim angle can cause loss of control.
1. Stop the angle.
  2. Place the tilt lock in the release position.

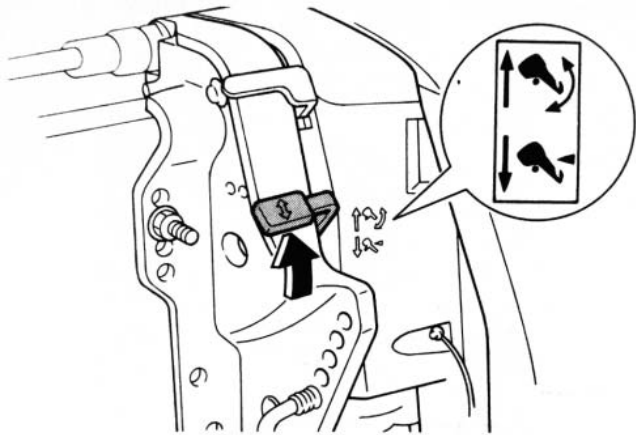

3. Hold the rear of the top cowling with one hand and tilt the engine to the desired angle.

4. Place the tilt lock lever back into the lock position to support the engine.

To raise the bow (trim-out), press the switch “UP” (up).

To lower the bow (trim-in), press the switch “DN” (down).

Make test runs the set to different angle to find the position that works best for your boat and operating conditions.

### **Adjusting boat trim**

When the boat is on plane, a bow-up attitude results in less drag, greater stability and efficiency. This is generally when the keel line of the boat is up about 3 to 5 degrees. With the bow up, the boat may have a greater tendency to steer to one side or the other. Compensate for this as you steer. When the bow of the boat is down, it is easier to accelerate from a standing start onto plane.

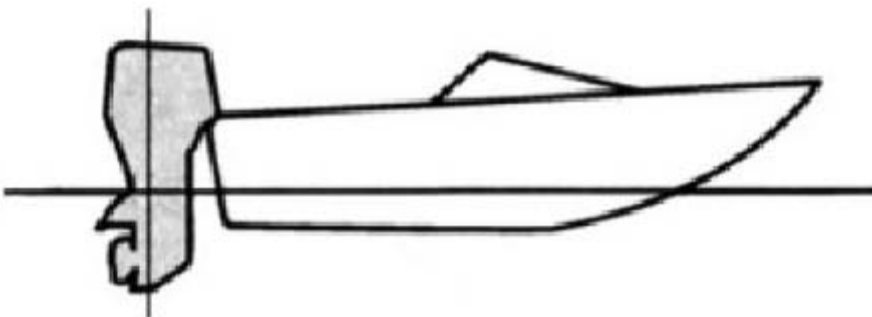

### **Bow up**

Too much trim-out puts the bow of the boat too high in the water. Performance and economy are decreased because the hull of the boat is pushing the water and there is more air drag. Excessive trim-out can also cause the propeller to ventilate, which reduces performance further, and the boat may “porpoise”(hop in the water),which could throw the

---

operator and passengers overboard.

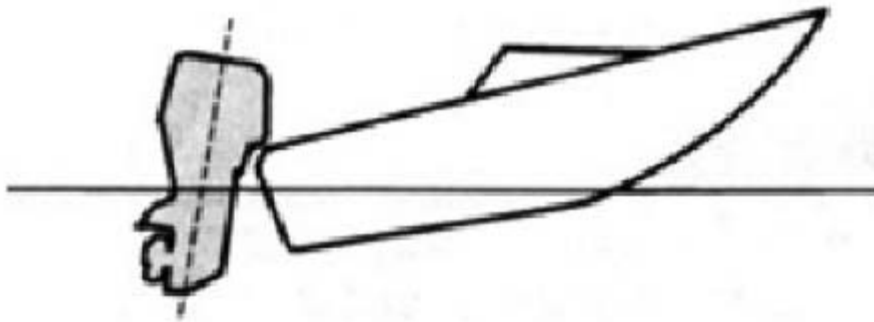

### **Bow Down**

Too much trim-in causes the boat to “plow” through the water, decreasing fuel economy and making it hard to increase speed. Operating with excessive trim-in at higher speeds also makes the boat unstable. Resistance at the bow is greatly increased, heightening the danger of “bow steering” and making operation difficult and dangerous.

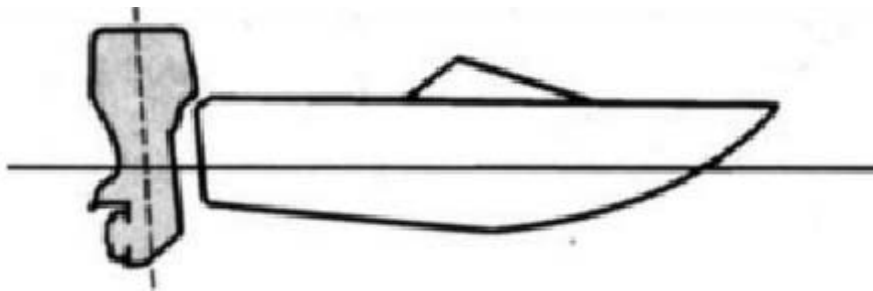

### **TIP:**

Depending on the type of boat, the outboard motor trim angle may have little effect on the trim of the boat when operating.

### **Tilting up and down**

If the engine will be stopped for some time or if the boat is moored in shallows, the outboard motor should be tilted up to protect the propeller and lower casing from damage by collision with obstructions, and also to reduce salt corrosion.

**⚠ WARNING** Make sure that no one is near the outboard motor when tilting the outboard motor up or down. Otherwise, body parts could be crushed between the outboard motor and the clamp bracket .

**⚠ WARNING** Leaking fuel is a fire hazard. If there is a fuel joint on the outboard motor, disconnect the fuel line or close the fuel cock if the engine will be tilted for

---

more than a few minutes. Otherwise fuel may leak.

**NOTICE:**

- Before tilting the outboard motor, stop the engine by following the procedure on page 39. Never tilt the outboard motor while the engine is running. Severe damage from overheating can result.
- Do not tilt up the engine by pushing the tiller handle (if equipped) because this could break the handle.

### Procedure for tilting up (power trim and tilt models)

1. Place the remote control lever/gear shift lever in neutral.

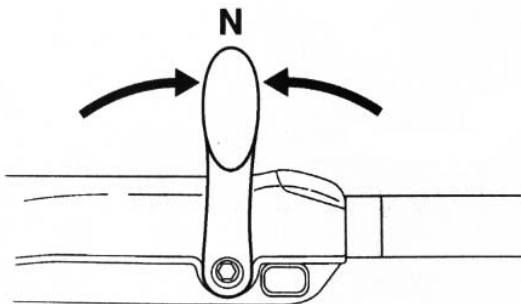
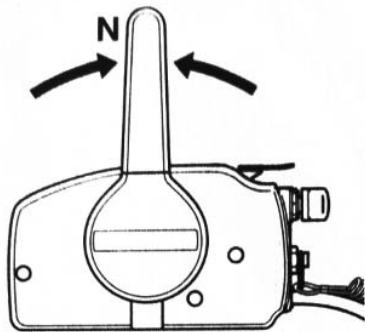

2. Press the power trim and tilt switch "UP" (up) until the outboard motor has tilted up completely.

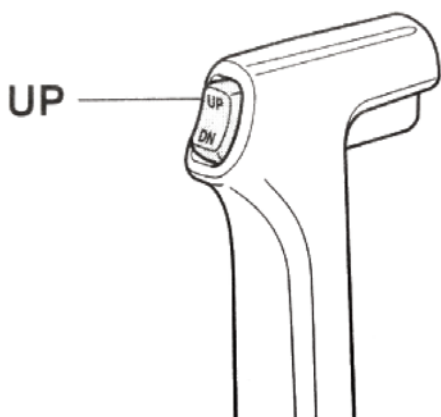

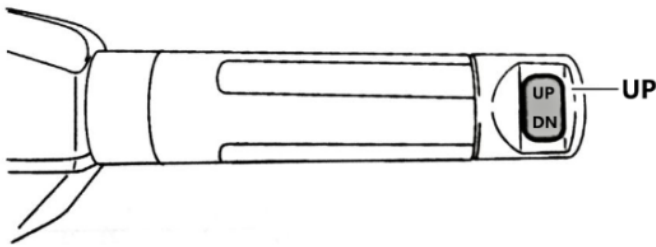
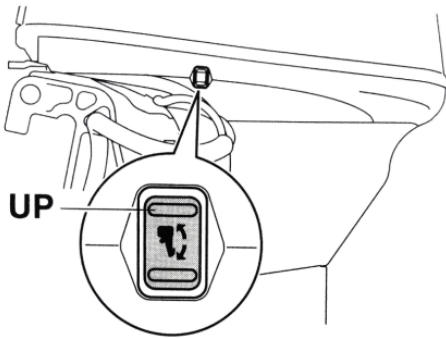

**3.** Pull the support lever toward you to support the engine. **WARNING!** After tilting the outboard motor, be sure to support it with the tilt support knob or tilt support lever. Otherwise the outboard could fall back down suddenly if oil in the power trim, and tilt unit or in the tilt unit loses pressure. **NOTICE:** Do not use the tilt support lever or knob when trailering the boat. The outboard motor could shake loose from the tilt support and fall. If the motor cannot be trailered in the normal running position, use an additional support device to secure it in the tilt position.

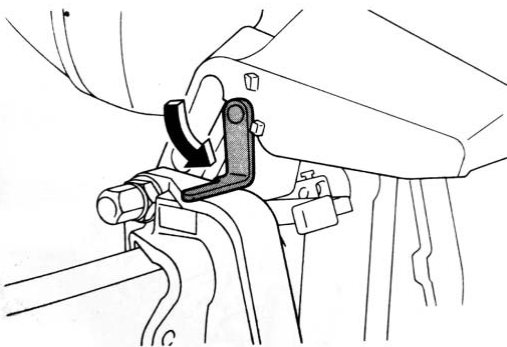

**Procedure for tilting down (power trim and tilt models)**

1. Push the power trim and tilt switch “UP”(up) until the outboard motor is supported by the rod and the tilt support lever become free.
2. Release the tile support lever.

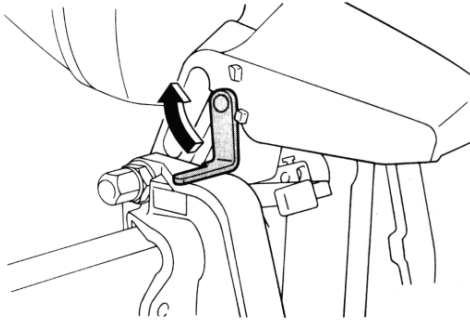

3. Push the power trim and tilt switch “DN”(down) to lower the outboard motor to the desired position.

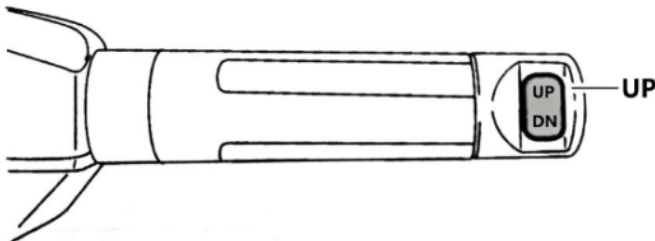
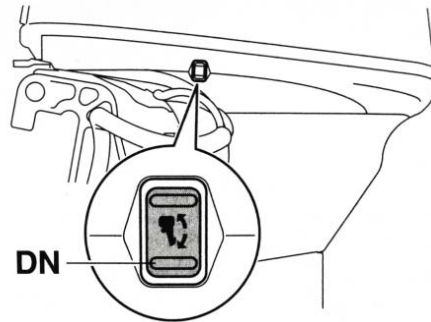
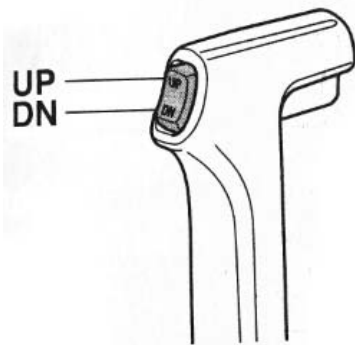

## Shallow water

### Hydro tilt models

The outboard motor can be tilted up partially to allow operation in shallow water.

#### **WARNING**

- Run the boat at the lowest possible speed when using the shallow water cruising system.
- Use extra care when operating in reverse. Too much reverse thrust can cause the outboard motor to lift out of the water, increasing the chance of accident and personal injury.

---

**NOTICE:**

Do not tilt the outboard motor up to so that the cooling water inlet on the water unit is above the surface of the water when setting up for and cruising in shallow water. Otherwise severe damage from overheating can result.

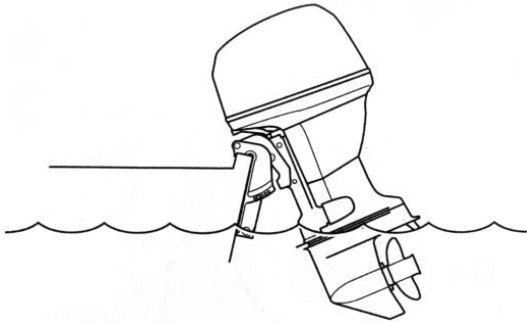

**Procedure for power trim and tilt models.**

1. Place the remote control lever / gear shift lever in neutral.

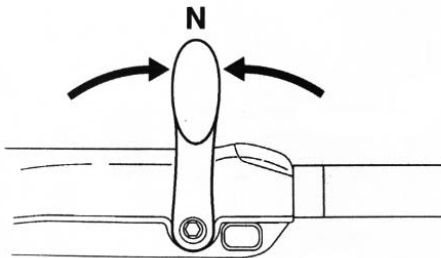
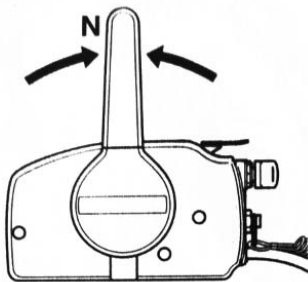

2. Slightly tilt the outboard motor up to the desired position using the power trim and tilt switch. **WARNING!** Using the power trim and tilt switch in the bottom cowling while the boat is moving or engine is on falling overboard and could distract the operator, increasing the risk of collision with another boar or an obstacle.

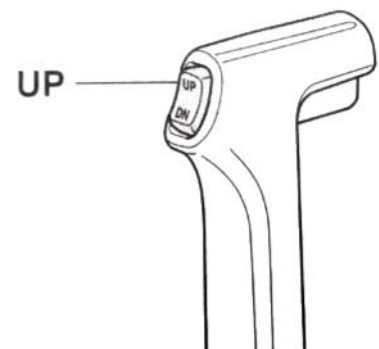



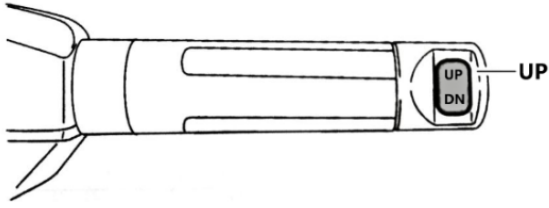

3. To return the outboard motor to the normal running position, press the power trim and tilt the outboard motor down.

## **Cruising in other conditions**

### **Cruising in salt water**

After operating in salt water, flushing the cooling water passages with fresh water to prevent them from becoming clogged. Also rinse the outside of the outboard motor with fresh water.

### **Cruising in muddy, turbid, or acidic water.**

Water in some areas can be acidic or with a lot of sediment in it, such as muddy or turbid (cloudy) water. After operating in such water, flush the cooling passages with fresh water to prevent corrosion. Also rinse the outside of the outboard motor with fresh water.

## **Maintenance**

### **Transporting and storing outboard motor**

#### **⚠ WARNING**

- USE CARE when transporting fuel tank, whether in a boat or car.
- Do NOT fill fuel container to maximum capacity. Gasoline will expand considerably as it warms up and can build up pressure in the fuel container. This can cause fuel leakage and a potential fire hazard.
- Leaking fuel is a fire hazard. When transporting and storing the outboard motor, disconnect the fuel line from the outboard motor to prevent fuel from leaking.
- Never get under the outboard motor while it is tilted. Severe injury could occur if the outboard motor accidentally falls.
- Do not use the tilt support lever or knob when trailering the boat. The outboard motor could shake loose from the tilt support and fall. If the outboard motor cannot be trailered in

---

the normal running position, use an additional support device to secure it in the tilt position.

**NOTICE:**

**When storing the outboard motor for prolonged time, fuel must be drained from the fuel tank. The deteriorated fuel could clog the fuel line causing engine start difficulty or malfunction.**

When storing or transporting the outboard motor, make sure to follow the procedure listed below.

- Disconnect the fuel line from the outboard motor.
- Tighten the fuel tank cap and its air vent screw.
- Store the fuel tank in a well-ventilated place.
- Store the fuel tank in a place that is stable and not exposed to shocks.

When the outboard motor is tilted for a prolonged time for mooring or trailering the boat, make sure to follow the procedure listed below.

- Disconnect the fuel hose from the fuel joint on the outboard motor.
- Tighten the fuel tank cap and its air vent screw.

The outboard motor should be transported and stored in the normal running position. If there is insufficient road clearance in this position, then trailer the outboard motor in the tilt position using a motor support device such as a transom saver bar. Consult your dealer for further details.

### **Storing outboard motor**

When storing your outboard motor for prolonged periods of time (2 months or longer), several important procedures must be performed to prevent excessive damage. It is advisable to have your outboard motor serviced by an authorized dealer prior to storage. However, you, the owner, with a minimum of tools, can perform the following procedures.

**NOTICE:**

- To prevent problems which can be caused by oil entering the cylinder from the sump, keep the outboard motor in the attitude shown when transporting and storing it. If storing or transporting the outboard motor on its side (not up-right), put it on a cushion after draining

---

the engine oil.

- Do not place the outboard motor on its side before the cooling water has drained from it completely, otherwise water may enter the cylinder through the exhaust port and cause engine trouble.
- Store the outboard motor in a dry, well-ventilated place, not in direct sunlight.
- Drain the remaining gasoline from the vapor separator. Gasoline left in the vapor separator for a prolonged period of time will break down and could cause damage to the fuel line.

## Procedure

### Flushing in a test tank

#### **NOTICE:**

**Do not run the engine without supplying it with cooling water. Either the engine water pump will be damaged or the engine will be damaged from overheating.**

Cooling system flushing is essential to prevent the cooling system from clogging up with salt, sand, or dirt. In addition, fogging/lubricating of the engine is mandatory to prevent excessive engine damage due to rust. Perform the flushing and fogging at the same time.

1. Wash the outboard motor body using fresh water. **NOTICE: Do not spray water into the air intake.**
2. Disconnect the fuel hose from the fuel joint on the outboard motor or shut off the fuel valve if equipped.
3. Remove the engine top coving, flywheel cover, and propeller.
4. Install the flushing attachment over the cooling water inlet. **NOTICE: Do not run the engine without supplying it with cooling water. Either the engine water pump will be damaged or the engine will be damaged from overheating. Before starting the engine, be sure to supply water to the cooling water passages. Avoid running the outboard motor at high speed while on the flushing attachment, otherwise overheating could occur.**

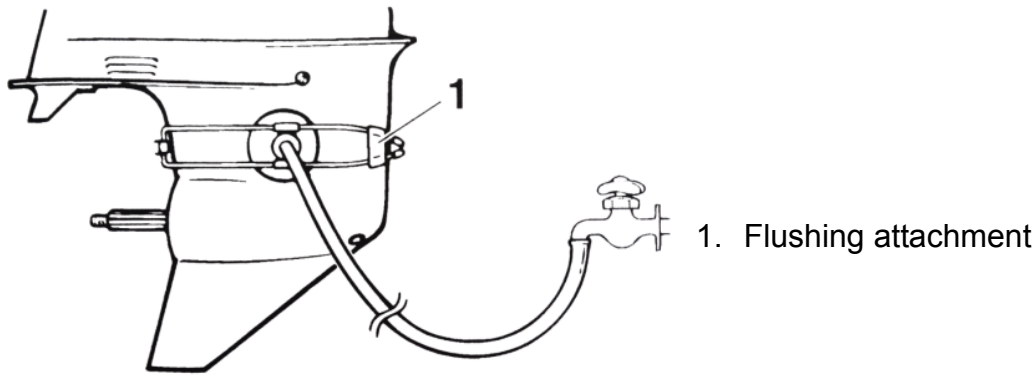

**TIP:**

- A flushing attachment is available from your dealer.
- When using the flushing attachment, maintain adequate water pressure and a steady water flow.

5. Run the engine at a fast idle for a few minutes in neutral position. **WARNING! Do not touch or remove electrical parts when starting or during operation. Keep hands, hair, and clothes away from the flywheel and other rotating parts while the engine is running.**

**TIP:**

If the overheat alert device is activated, turn the engine off, and consult your dealer.

6. Just prior to turning off the engine, quickly spray "Fogging Oil" on to the silencer cover. When properly done, the engine will almost stall.

**TIP:**

If the "Fogging Oil" is not available, remove the spark plug(s). Pour a teaspoonful of clean engine oil into each cylinder. Crank several times manually. Replace the spark plug(s).

7. Drain the remained gasoline in the vapor separator with a container. Loosen the drain screw, and then remove the cap. Push in the air valve with a screwdriver to introduce air into the float chamber, so that the gasoline will drain smoothly. Then, tighten the drain screw.

8. Remove the flushing attachment.

- 
9. Drain the cooling water completely out of the motor. Clean the body thoroughly.
  10. Install the flywheel cover, propeller, and top coving.
  11. Store the fuel tank in a dry, well-ventilated place, not in direct sunlight.

### Lubrication

1. Change the gear oil. Check the gear oil for the presence of water that indicates a leaky seal. Seal replacement should be performed by an authorized dealer prior to use.
2. Lubricate all grease fittings.

### TIP:

For long-term storage, fogging the engine with fogging oil is recommended. Contact your dealer or information about fogging oil and procedures for your outboard motor.

### Flushing power unit

Perform this procedure right after operation for the most thorough flushing.

### NOTICE:

**Do not perform this procedure while the engine is running. The water pump may be damaged and severe damage from overheating can result.**

1. After shutting off the engine, unscrew the garden hose connector from the fitting on the bottom cooling.

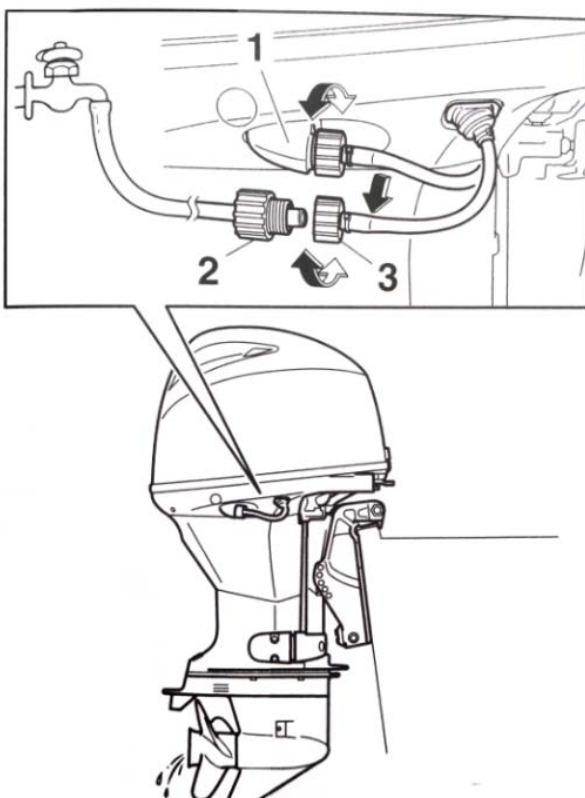

1. Fitting
2. Garden hose adapter
3. Garden hose connector

- 
2. Screw the garden hose adapter onto a garden hose, which is connected to a fresh water supply, and then connect it to the garden hose connector.
  3. With the engine off, turn on the water tap and let the water flushing through the cooling passages for about 15 minutes. Turn off the water and disconnect the garden hose adapter from the garden hose connector.
  4. Reinstall the garden hose connector onto the fitting on the bottom cowling. Tighten the connector securely. **NOTICE: Do not leave the garden hose connector loose on the bottom cowling fitting or let the hose hang free during normal operation. Water will leak out of the connector instead of cooling the engine, which can cause serious overheating. Be sure the connector is tightened securely on the fitting after flushing the engine.**

**TIP:**

- When flushing the engine with the boat in the water, tilting up the outboard motor until it is completely out of the water will achieve better results.
- For cooling system flushing instructions

**Cleaning the outboard motor**

When cleaning the outboard motor, the top cowling must be installed.

1. Wash the exterior of the outboard motor using fresh water. **NOTICE: Do not spray water into the air intake.**

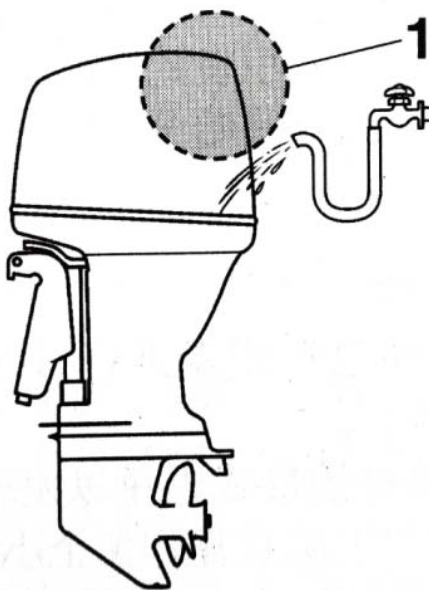

1. Air intake

---

2. Drain the cooling water completely out of the outboard motor. Clean the body thoroughly.

### **Checking painted surface of outboard motor**

Check the outboard motor for scratches, nicks, or flaking paint. Areas with damaged paint are more likely to corrode. If necessary, clean and paint the areas. A touch-up paint is available from your dealer.

## **Periodic maintenance**



**These procedures require mechanical skills, tools, and supplies. If you do not have the proper skills, tools, or supplies to perform a maintenance procedure, have a dealer or other qualified mechanic do the work.**

**The procedures involve disassembling the motor and exposing dangerous parts. To reduce the risk or injury from moving hot, or electrical parts:**

- **Turn off the engine and keep the key(s) and engine shut-off cord (lanyard) with you when perform maintenance unless otherwise specified.**
- **The power trim and tilt switches operate even when the ignition key is off. Keep people away from the switches whenever working around the motor. When the motor is tilted, keep away from the area under it or between it and the clamp bracket. Be sure no one is in this area before operating the power this and tilt mechanism.**
- **Allow the engine to cool before handling hot parts or fluids.**
- **Always completely reassemble the motor before operation.**

### **Replacement parts**

If replacement parts are necessary, use only genuine our parts or parts of equivalent design and quality. Any part of inferior quality may malfunction, and the resulting loss of control could endanger the operator and passengers. Our genuine parts and accessories are available from your dealer.

### **Severe operating conditions**

Severe operating conditions involve one or more of the following types of operation on a regular basis:

- **Operating continuously at or near maximum engine speed (rpm) for many hours.**
- **Operating continuously at a low engine speed (rpm) for many hours.**

- 
- **Operating without sufficient time for engine to warm up and cool down.**
  - **Frequent quick acceleration and deceleration.**
  - **Frequent shifting.**
  - **Frequently starting and stopping the engine(s).**
  - **Operation that fluctuates often between light and heavy cargo loads.**

Outboard motors operating under any of these above conditions require more frequent maintenance. We recommend that you do this service twice as often as specified in the maintenance chart. For example, if a particular service should be done at 50 hours, do it instead at 25 hours. This will help prevent more rapid deterioration of engine components



## Maintenance chart 1

### TIP:

- Refer to the sections in this chapter for explanations of each owner-specific action.
- The maintenance cycle on these charts assume usage of 100 hours per year and regular flushing of the cooling water passages. Maintenance frequency should be adjusted when operating the engine under adverse conditions such as extended trolling.
- Disassembly or repairs may be necessary depending on the outcome of maintenance checks.
- Expendable or consumable parts and lubricants will lose their effectiveness over time and through normal usage regardless of the warranty period.
- When operating in salt water, muddy, other turbid (cloudy) ,acidic water, the engine should be flushed with clean water after each use.

The"●"symbol indicates the check-ups which you may carry out yourself.

The"○"symbol indicates work to be carried out by your dealer.

Item	Actions	Initial	Every			page
		20 hours (3months)	100 hours (1 year)	300 hours (3 years)	500 hours (5 years)	
Anode(s) (external)	Inspection or replacement as necessary		●/○			87
Anode(s) (internal)*1	Inspection or replacement as necessary		○			—
Anode(s) (internal)*2	Replacement				○	—
Battery (electrolyte level, terminal)	Inspection	●/○	●/○			88
Battery (electrolyte level, terminal)	Fill, changing or replacing as necessary		○			—
Cooling water leakage	Inspection or replacement as necessary	○	○			—
Cowling lock lever	Inspection		●/○			41,42
Engine starting condition/noise	Inspection	●/○	●/○			48
Engine starting speed/noise	Inspection	●/○	●/○			80
Engine oil	Replacement	●/○	●/○			80
Engine oil fitter(cartridge)	Replacement		●/○			—
Fuel filter (can be disassembled)	Inspection or replacement as necessary	●/○	●/○			34
Fuel line(High pressure)	Inspection	●	●			—

Fuel line(High pressure)	Inspection or replacement as necessary	○	○			—
Fuel line(Low pressure)	Inspection	●	●			—
Fuel line(Low pressure)	Inspection or replacement as necessary	○	○			—
Fuel pump	Inspection or replacement as necessary			○		—
Fuel/engine oil leakage	Inspection	○	○			—
Gear oil	Replacement	●/○	●/○			86
Greasing points	Greasing	●/○	●/○			78
Clamp bracket bolt (through tube)	Inspection and greasing		○			—
Impeller/water pump housing	Inspection or replacement as necessary		○			—
Impeller/water pump housing	Replacement			○		—
Power trim and tilt unit	Inspection	●/○	●/○			44
Propeller/propeller nut/cotter pin	Inspection or replacement as necessary	●/○	●/○			83
Shift link/shift cable	Inspection, adjustment or replacement as necessary	○	○			—
Spark plug(s)	Inspection or replacement as necessary		●/○			79
Spark plug caps/spark plug wires	Inspection or replacement as necessary	○	○			—
Shift Dampener System (SDS) propeller damper	Inspection or replacement		○			—
Water from the cooling water pilot hole	Inspection	●/○	●/○			54
Throttle link/throttle cable	Inspection, adjustment or replacement as necessary	○	○			—
Thermostat	Inspection or replacement as necessary		○			—
Timing belt	Inspection or replacement as necessary		●/○			—
Valve clearance	Inspection and adjustment			○		—
Cooling water inter	Inspection	●/○	●/○			18
Main switch/stop switch	Fill, changing or replacing as	○	○			—

	necessary					
Wire harness connections/wire coupler connections	Inspection or replacement as necessary	○	○			—
Meter/gauge	Inspection	○	○			—
Fuel tank (portable tank)	Inspection and cleaning as necessary		○			—

\*1 cylinder head, thermostat cover

\*2 exhaust cover, cooling water passage cover. Rectifier Regulator cover

### Maintenance chart 2

Item	Actions	Every	Page
		1000 hours	
Exhaust guide/exhaust manifold	Inspection or replacement as necessary	○	—
Timing belt	Replacement	○	—

---

## Greasing

Grease A (water resistant grease)

Grease D (corrosion resistant grease, for propeller shaft).

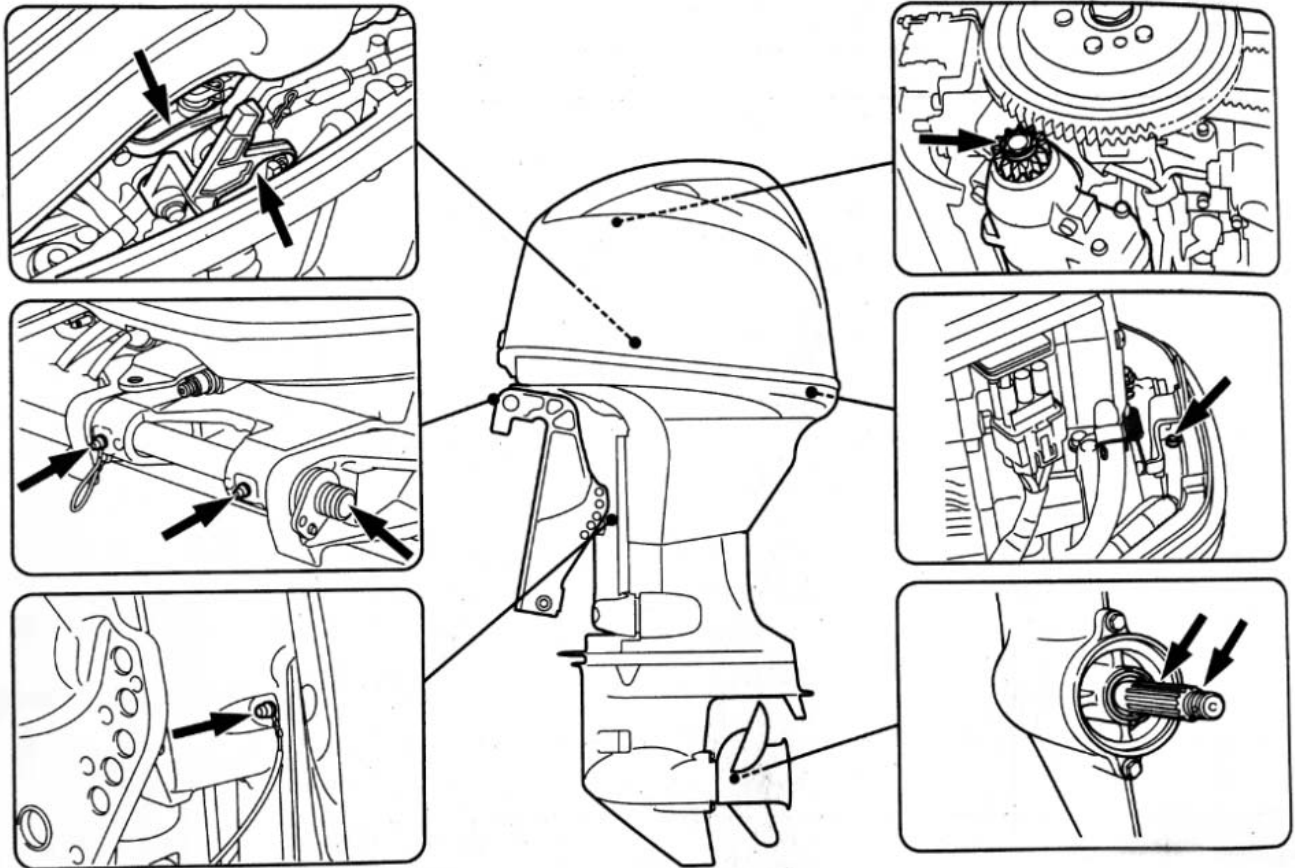

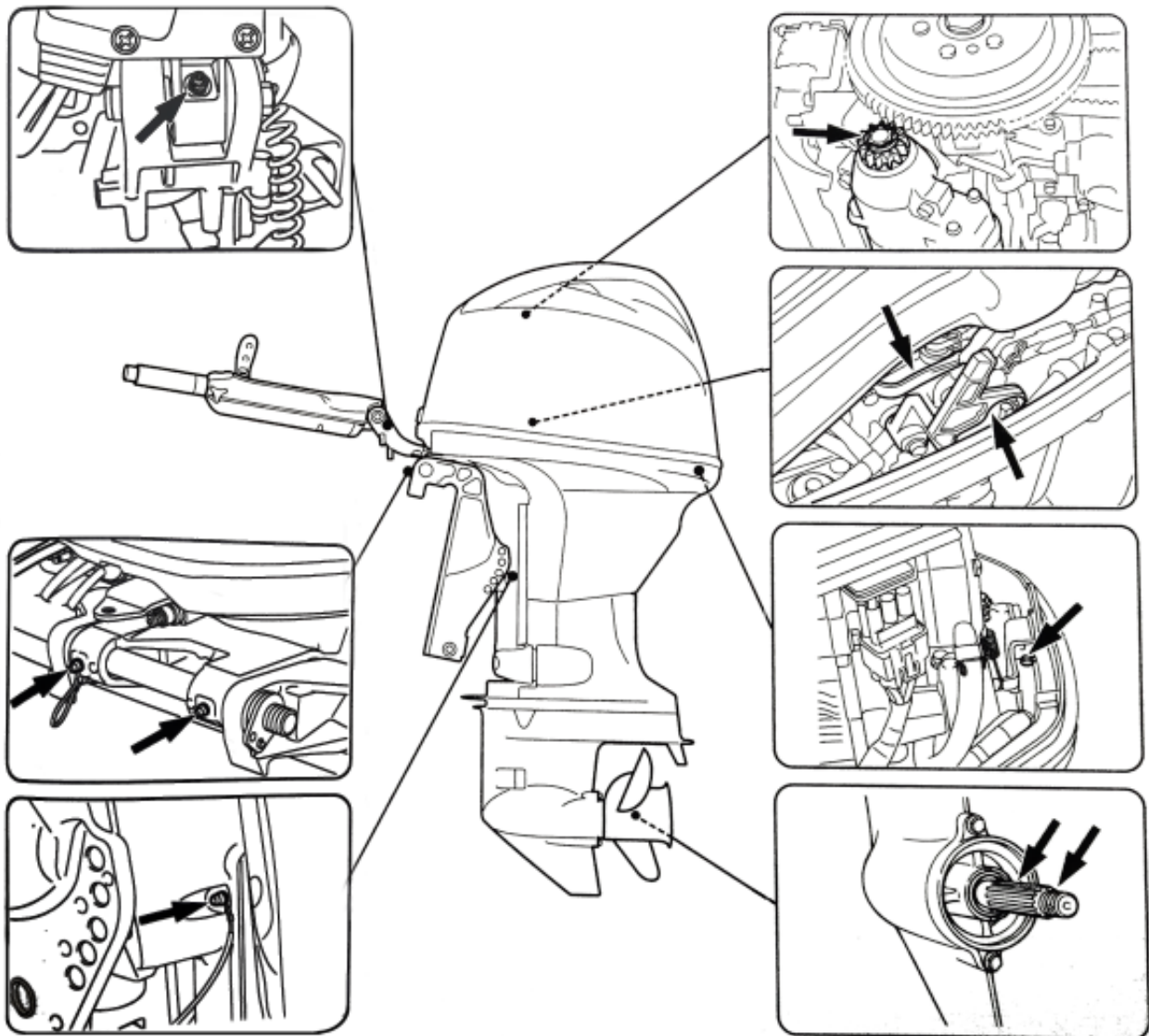

### **Cleaning and adjusting spark plug**

The spark plug is an important engine component and is easy to inspect. The condition of the spark plug can indicate something about the condition of the engine. For example, if the center electrode porcelain is very white, this could indicate an intake air leak or carburetion problem in that cylinder. Do not attempt to diagnose any problems yourself. Instead, take the outboard motor to a dealer. You should periodically remove and inspect the spark plug because heat and deposits will cause the spark plug to slowly break down and erode.

1. Remove the spark plug caps from the spark plugs.
2. Remove the spark plug. If electrode erosion becomes excessive, or if carbon and other deposits are excessive, you should replace the spark plug with another of the correct type.

**WARNING! When removing or installing a spark plug, be careful not to damage the insulator. A damaged insulator could allow external sparks, which could lead to**

---

**explosion or fire.**

Standard spark plug:  
DPR6EB-9

3. Be sure to use the specified spark plug, otherwise the engine may not operate properly. Before fitting the spark plug, measure the electrode gap with a wire thickness gauge; replace it if out of specification.

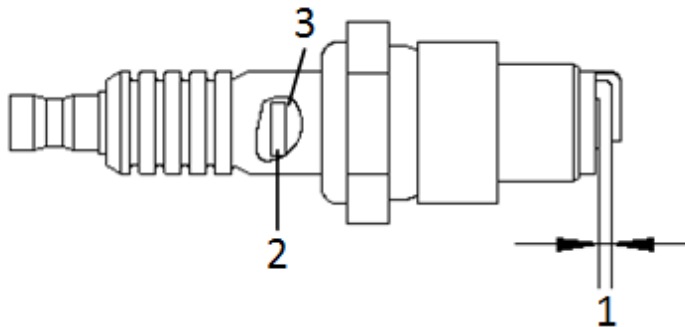

1. Spark plug gap
2. Spark plug part number
3. Spark plug I.D. mark (NGK)

Spark plug gap:  
0.8-0.9mm(0.031-0.035in)

4. When fitting the plug, wipe off any dirt from the threads, and then screw it in to the correct torque.

Spark plug torque:  
17Nm(1.73kgf-m, 12.5ft-lb)

**TIP:**

If a torque-wrench is not available when you are reinstalling a spark plug, a good estimate of the correct torque is 1/12 turn past finger tight. When you are installing a new spark plug, a good estimate of the correct torque is 1/2 turn past finger-tight.

**Inspecting idle speed**



- Do not touch or remove electrical parts when starting or during operation.
- Keep hands, hair, and cloths away from the flywheel and other rotating parts while the engine is running.

**NOTICE:**

This procedure must be performed while the outboard motor is in the water. A flushing attachment or test tank can be used.

---

If the boat is not equipped with a tachometer for the outboard motor, use a diagnostic tachometer for this procedure. Results may vary depending on whether testing is conducted with the flushing attachment, in a test tank, or with the outboard motor in the water.

1. Start the engine and allow in to warm up fully in neutral until it is running smoothly.
2. Once the engine has warmed up, verify whether the idle speed is set to specification. If you have difficulty verifying the idle speed, or the idle speed requires adjustment, consult a dealer or other qualified mechanic.

## Changing engine oil



- **Avoid draining the engine oil immediately after stopping the engine. The oil is not hot and should be handle with care to avoid burns .**
- **Be sure the outboard motor is securely fastened to the transom or a stable stand.**

### **NOTICE:**

**Change the engine oil after the first 20 hours of operation or 3 months, and every 100 hours or at 1-year intervals there-after. Otherwise the engine will wear quickly.**

To prevent spilling oil where it could cause damage to nature, it is strongly recommended that you use an oil changer or change the engine oil. If an oil changer is not available, drain the engine oil by removing the drain screw. If you are not familiar with the procedure for changing the engine oil, consult your dealer.

1. Put the outboard motor in an upright position (not tilted), **NOTICE: If the outboard motor is not level, the oil level indicated on the oil dipstick may not be accurate.**

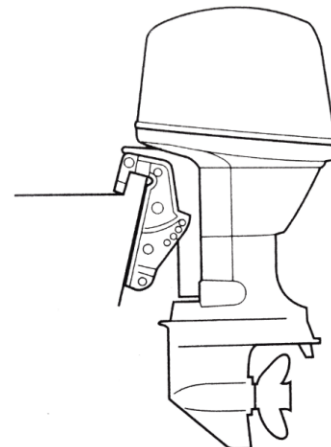

2. Start the engine. Warm it up and keep the idle speed for 5-10 minutes.

- 
3. Stop the engine and leave it for 5-10 minutes.
  4. Remove the top cowling.
  5. Remove the oil filler cap. Pull out the dipstick and use the oil changer to extract the oil completely.

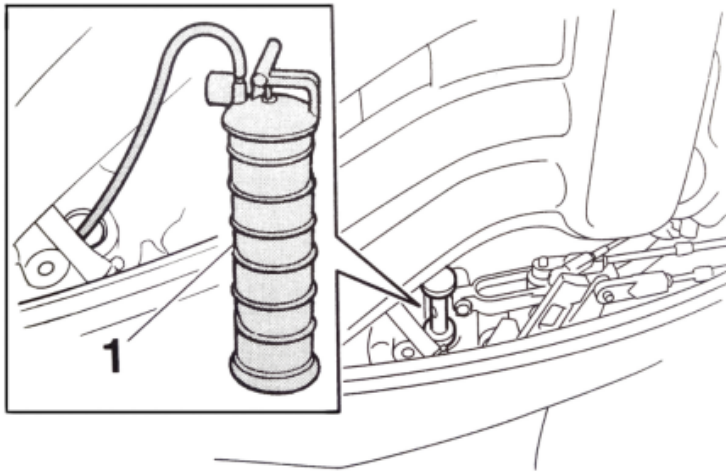

1. Oil changer

**TIP:**

When using an oil changer, skip steps 6 and 7.

6. Prepare a suitable container that holds a larger amount than the engine oil capacity. Remove the drain screw and gasket while holding the container under the drain hole. Let the oil drain completely. Wipe up any spilled oil immediately.

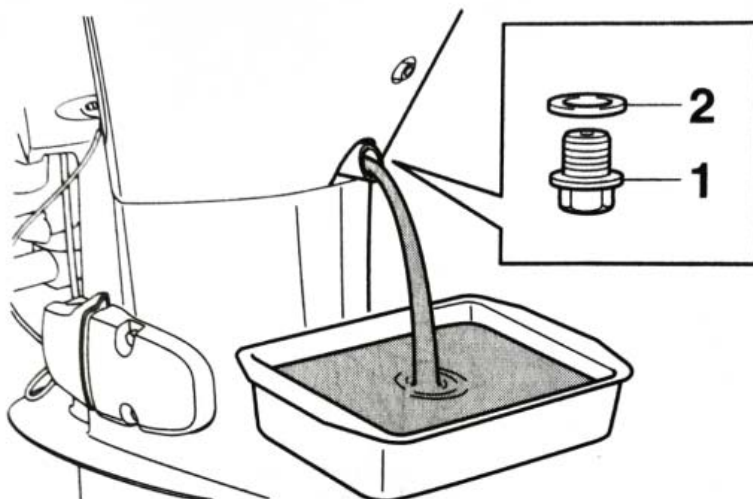

1. Drain screw

2. Gasket

**TIP:**

If the oil does not drain easily, change the tilt angle or turn the outboard motor to port and starboard to drain the oil.

7. Put a new gasket on the oil drain screw. Apply a light coat of oil to the gasket and install



---

the drain screw.

Drain screw tightening torque:  
27 Nm (2075 kgf -m, 19.9 ft-lb)

**TIP:**

If a torque wrench is not available when you are installing the drain screw, finger tighten the screw just until the gasket comes into contact with the surface of the drain hole. Then tighten 1/4 to 1/2 turn more. Tighten the drain screw to the correct torque with a torque wrench as soon as possible.

8. Add the correct amount of oil through the filler hole. Put back the filler cap and the dipstick. **NOTICE: Overfilling the oil could cause leakage or damage. If the oil level is above the upper level mark, drain until the level meets the specified capacity.**

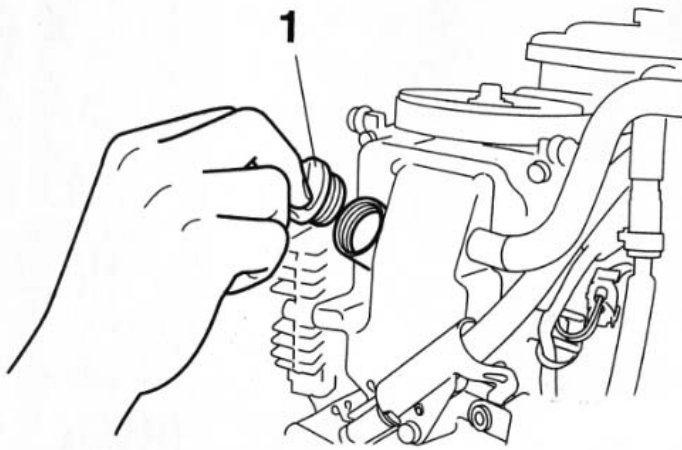

1. Oil filler cap

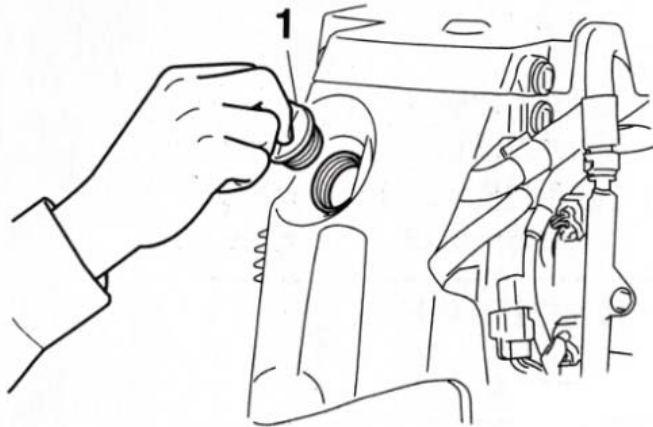

1. Oil filler cap

Recommended engine oil:

4-stroke outboard motor oil

Engine oil quantity (without oil filter replacement):

1.9 L (2.01 US qt, 1.67 Imp-qt)

Engine oil quantity (with oil filter replacement):

2.1 L (2.22 US qt, 1.85 Imp-qt)

9. Leave the outboard motor for 5-10 minutes.

10. Remove the oil dipstick and wipe it clean.

11. Insert the dipstick and remove it again. Be sure to completely insert the dipstick into the dipstick guide, otherwise the oil level measurement will be incorrect.

12. Recheck the oil level using the dipstick to be sure the level falls between the upper and lower marks. Consult your dealer if the oil level is out of specified level.

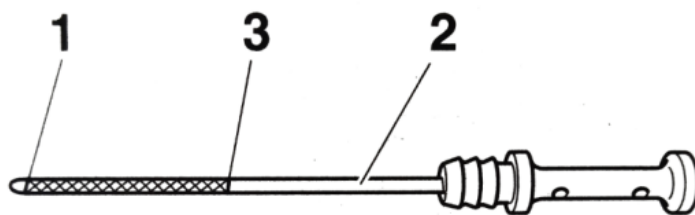

1. Lower mark

2. Oil dipstick

3. Upper mark

13. Start the engine and make sure that the low oil pressure-alert indicator remains off. Also, make sure that there are no oil leaks. **NOTICE: If the low oil pressure-alert indicator comes on or if there are oil leaks, stop the engine and find the cause. Continued operation with a problem could cause severe engine damage. Consult your dealer if the problem cannot be located and corrected.**

14. Install the top cowling.

15. Dispose of used oil according to local regulations.

**TIP:**

- For more information on the disposal of used oil, consult your dealer.
- Change the oil more often when operating the engine under adverse conditions such as extended trolling.

---

## Inspecting wiring and connectors

- Inspect that each connector is engaged securely.
- Inspect that each ground lead is properly secured.

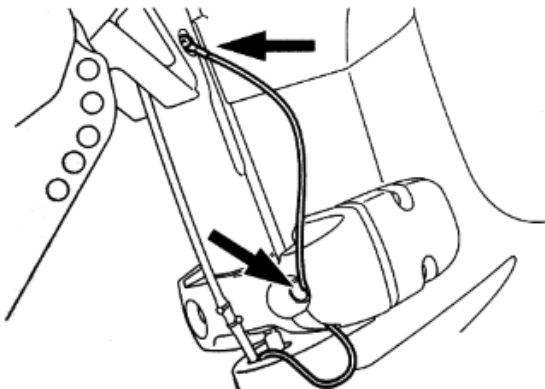
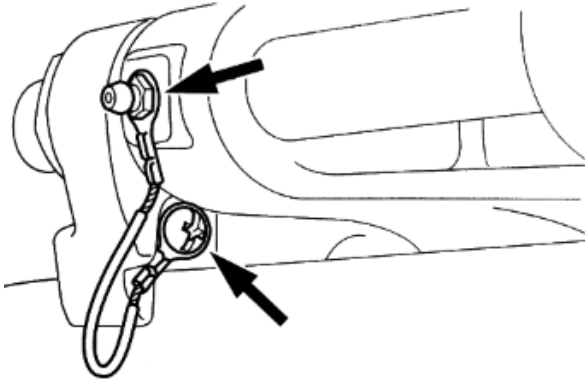

## Checking propeller

### **WARNING**

You could be seriously injured if the engine accidentally starts when you are near the propeller. Before inspecting, removing, or installing the propeller, place the shift control in neutral, turn the main switch to “OFF” (off) and remove the key, and remove the clip from the engine shut-off switch. Turn off the battery out-off switch if you boat has one.

Do not use your hand to hold the propeller when loosening or tightening the propeller nut. Put a wood block between the anti-cavitation plate and the propeller to prevent the propeller from turning.

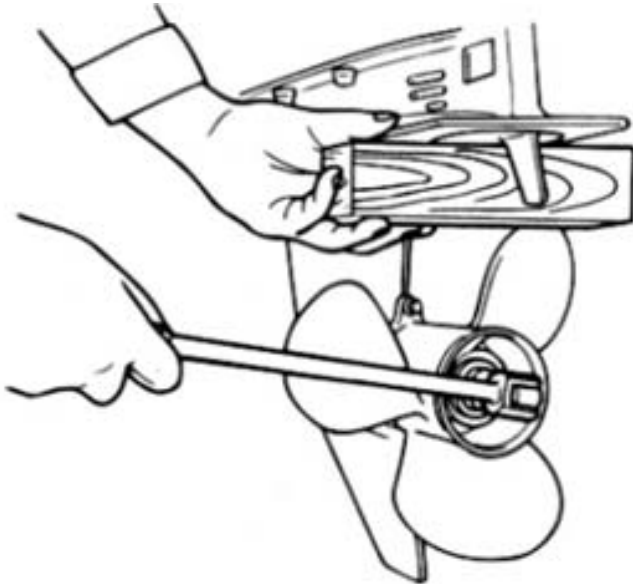

### Checkpoints

- Check each of the propeller blades for erosion from cavitation or ventilation, or other damage.
- Check the propeller shaft damage.
- Check the splines for wear or damage.
- Check for fish line tangled around the propeller shaft.

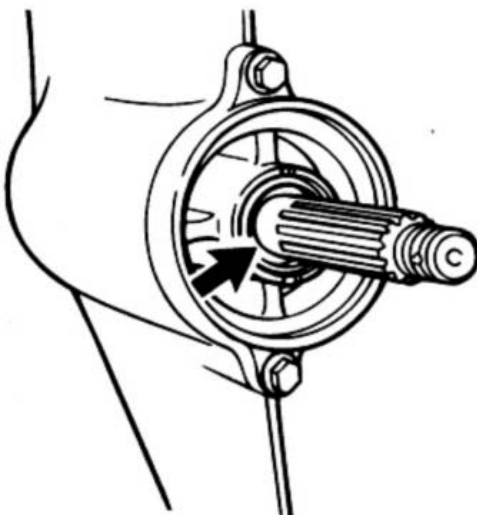

- Check the propeller shaft oil seal for damage.

### Removing propeller

#### Spline models

1. Straighten the cotter pin and pull it out using a pair of pliers.

2. Remove the propeller nut, washer, and spacer (if equipped). **WARNING!** Do not use your hand to hold the propeller when loosening the propeller nut.

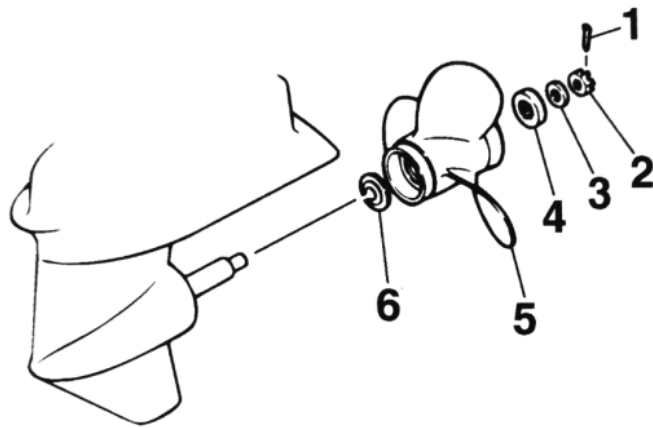

1. Cotter pin
2. Propeller nut
3. Washer
4. Spacer
5. Propeller
6. Thrush washer

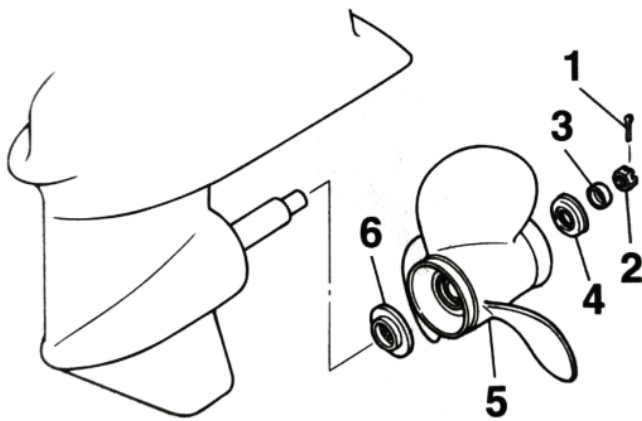

1. Cotter pin
2. Propeller nut
3. Washer
4. Spacer
5. Propeller
6. Thrush washer

3. Remove the propeller, washer (if equipped), and thrust washer.

## Installing propeller

### Spline models

#### **NOTICE:**

**Make sure to use a new cotter pin and bend the ends over securely. Otherwise, the propeller could come off during operation and be lost.**

1. Apply Marine grease or a corrosion resistant grease to the propeller shaft.
2. Install the spacer (if equipped), thrust washer, washer (if equipped), and propeller on the propeller shaft. **NOTICE: Make sure to install the thrust washer before installing the propeller. Otherwise, the lower case and propeller boss could be damage.**
3. Install the spacer (if equipped) and the washer, Tighten the propeller nut to the specified torque.

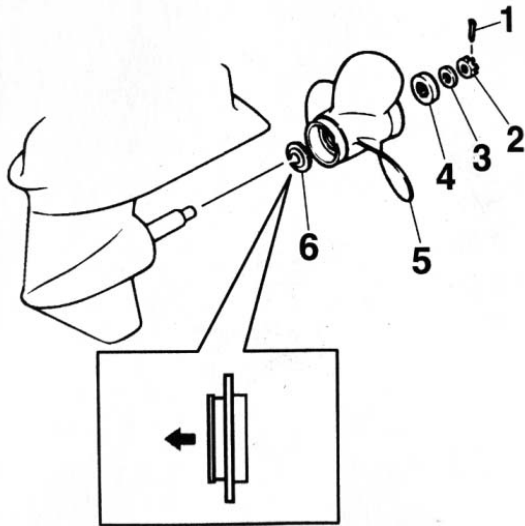

1. Cotter pin
2. Propeller nut
3. Washer
4. Spacer
5. Propeller
6. Thrust washer

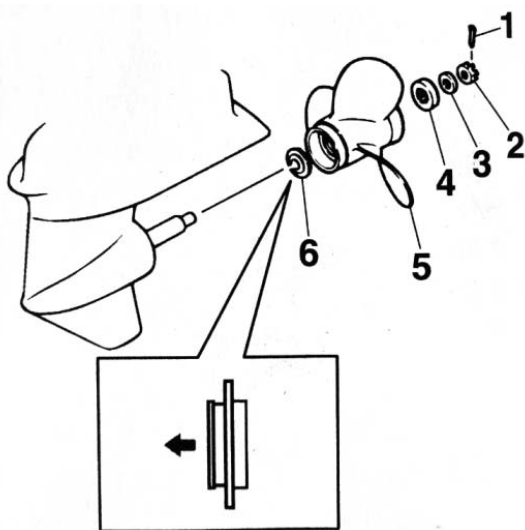

1. Cotter pin
2. Propeller nut
3. Washer
4. Spacer
5. Propeller
6. Thrust washer

**Propeller nut tightening torque:**

34 nm (3.47 kgf-m, 25.1 ft-lb)

4. Align the propeller nut slot with the propeller shaft hole. Insert a new cotter pin in the hole and bend the cotter pin ends. **NOTICE: Do not reuse the cotter pin. Otherwise, the propeller can come off during operation.**

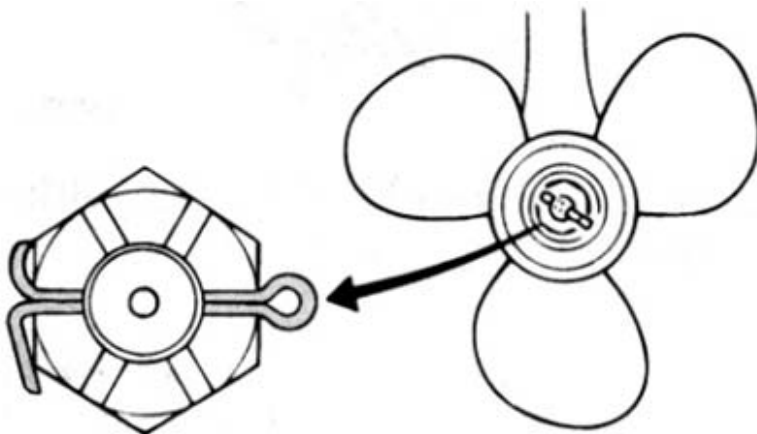

---

**TIP:**

If the propeller nut slot does not align with the propeller shaft hole after tightening the propeller nut to the specified torque, tighten the nut further to align the slot with the hole.

**Changing gear oil**

- **Be sure the outboard motor is securely fastened to the transom or a stable stand. You could be severely injured if the outboard motor falls on you.**

- **Never get under the lower unit while it is tilted, even when the tilt support lever or knob is locked. Severely injury could occur if the outboard motor accidentally falls.**

1. Tilt the outboard motor so that the gear oil drain screw is at the lowest point possible.
2. Place a suitable container under the gear case.
3. Remove the gear oil drain screw and gasket. *NOTICE:* If there is an excessive quantity of metal particles on the magnetic gear oil drain screw, this can indicate lower unit problem. Consult your dealer.

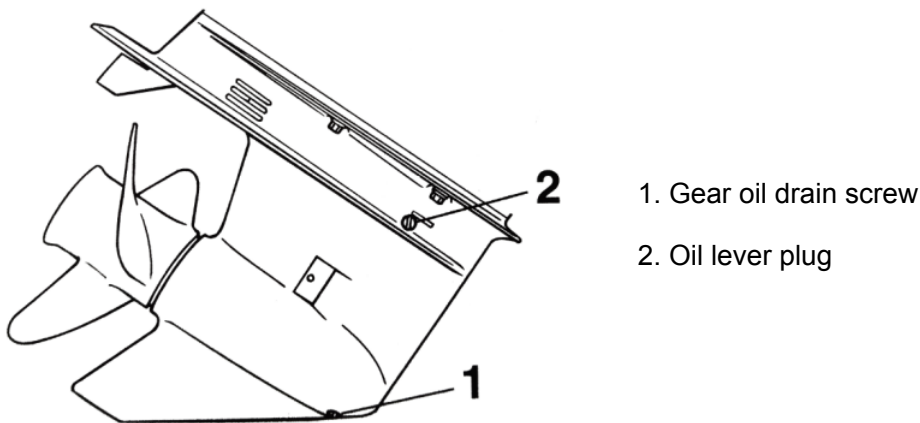
**TIP:**

- If a magnetic gear oil drain screw is equipped, remove all metal particles from the screw before installing it.

- Always use new gaskets. Do not reuse the moved gaskets.

4. Remove the oil level plug and gasket to allow the oil to drain completely.

***NOTICE:* Check the used gear oil after it has been drained. If the gear oil is milky or contains water or large amount of metal particles, the gear case may be damaged.**

---

**Have a dealer check and repair the outboard motor.**

**TIP:**

For disposal of used oil, consult your dealer.

5. Put the outboard motor in a vertical position. Using a flexible or pressurized filling device, inject the gear oil into the gear oil drain screw hole.

**Recommended gear oil:**

Hypoid gear oil

**Recommended gear oil grade:**

SAE 90 API GL - 4

**Gear oil quantity:**

0.430L (0.455 US qt, 0.348 Imp-qt)

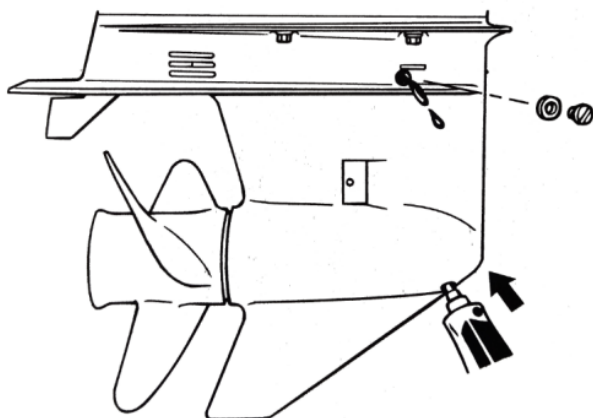

6. Put a new gasket on the oil level plug. When the oil begins to flow out of the oil level plug hole. Insert and tighten the oil level plug.

Tightening torque:

7 Nm (0.71 kgf-m, 5.2 ft-lb)

7. Put a new gasket on the gear oil drain screw. Insert and tighten the gear oil drain screw.

Tightening fuel tank:

7 Nm (0.71 kgf-m, 5.2 ft-lb)



---

## Cleaning fuel tank



Gasoline is highly flammable, and its vapors are flammable and explosive.

- If you have any question about properly doing this procedure, consult your dealer.
  - Keep away from sparks, cigarettes, flames, or other sources of ignition when cleaning the fuel tank.
  - Remove the fuel tank from the boat before cleaning it. Work only outdoors in an area with good ventilation.
  - Wipe up any spilled fuel immediately.
  - Reassemble the fuel tank carefully. Improper assembly can result in a fuel leak, which could result in a fire or explosion hazard.
  - Dispose of old gasoline according to local regulations.
1. Empty the fuel tank into an approved container.
  2. Pour a small amount of suitable solvent into the tank. Install the cap and shake the tank. Drain the solvent completely.
  3. Remove the screws holding the fuel joint assembly. Pull the assembly out of the tank.

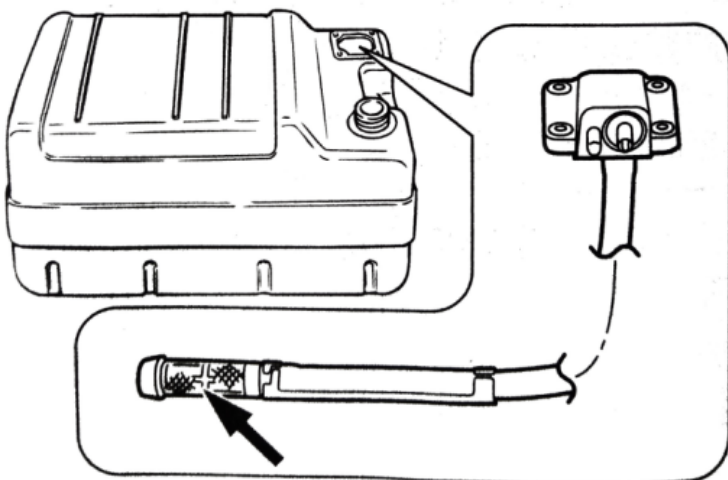

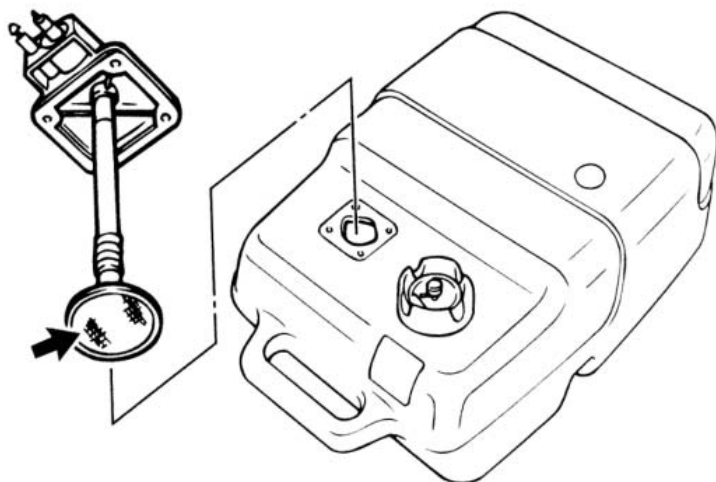

4. Clean the filter (located on the end of the suction pipe) in a suitable cleaning solvent. Allow the filter to dry.
5. Replace the gasket with a new one. Reinstall the fuel joint assembly and tighten the screws firmly.

### Inspecting and replacing anode(s)

Outboard motors are protected from corrosion by sacrificial anode. Inspect the external anode periodically. Remove scales from the surfaces of the anode. Consult a dealer for replacement of external anode.

**NOTICE:**

**Do not paint anodes, as this would render them ineffective.**

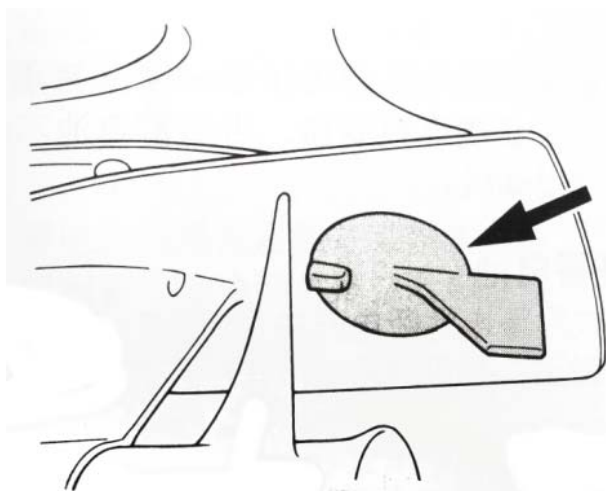

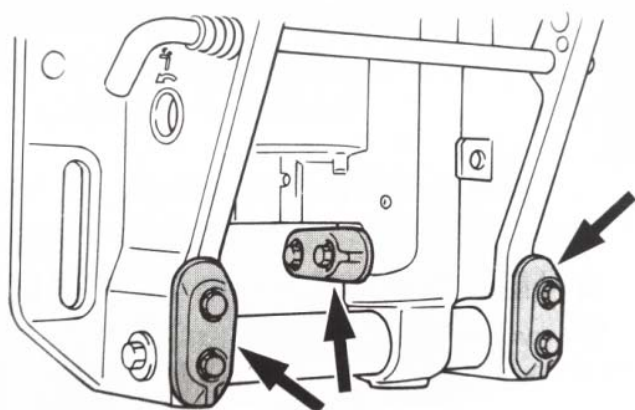
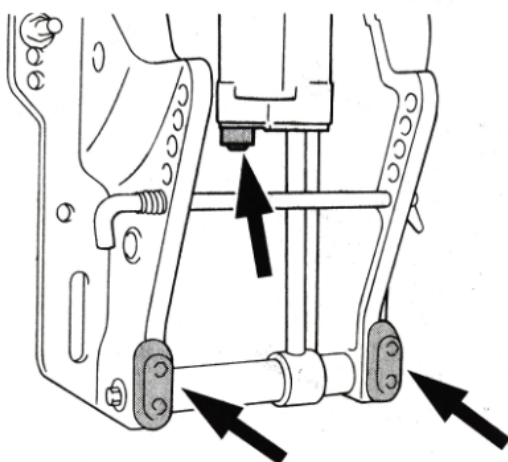
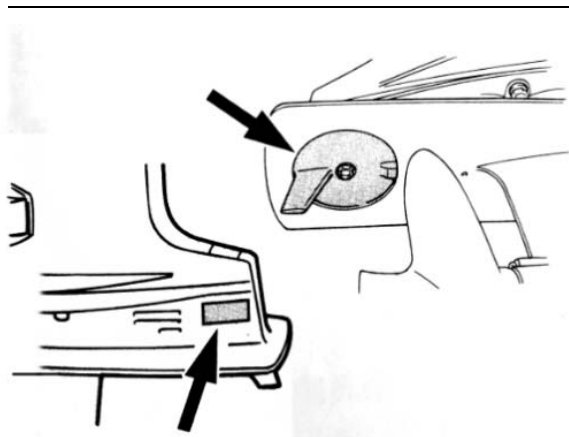

**TIP:**

Inspect ground leads attached to external anodes on equipped models. Consult a dealer for inspection and replacement of internal anodes attached to the power unit.

**Checking battery (for electric start models)**



**Battery electrolyte is poisonous and caustic, and batteries generate explosive hydrogen gas. When working near the battery:**

- 
- **Wear protective eye gear and rubber gloves.**
  - **Do not smoke or bring any other source of ignition near the battery.**

The procedure for checking the battery varies for different batteries. This procedure contains typical checks that apply to many batteries, but you should always refer to the battery manufacturer's instructions.

**NOTICE:**

**A poorly maintained battery will quickly deteriorate.**

1. Check the electrolyte level

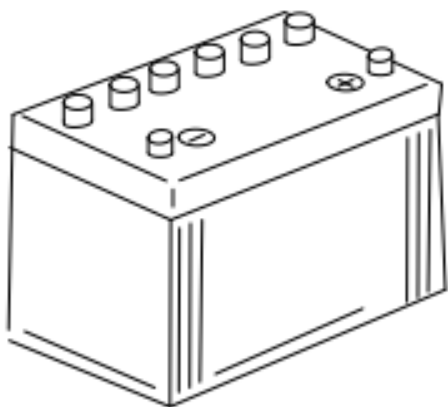

2. Check the battery's charge. If your boat is equipped with the digital speedometer, the voltmeter and low battery alert functions will help you monitor the battery's charge. If the battery needs charging, consult your dealer.

3. Check the battery connections. They should be clean, secure, and covered by an insulating cover. **WARNING! Bad connections can produce shorting or arcing and cause an explosion.**

**Connecting the battery**



Mount the battery holder securely in a dry, well-ventilated, vibration-free location in the boat. Install a fully charged battery in the holder.

**NOTICE:**

**Do not reverse the battery cables, Otherwise, the electrical parts could be damaged.**

1. Make sure the main switch ( on applicable models) is "OFF"(off) before working on the battery
2. Connect the red battery cable to the POSITIVE (+) terminal first, Then connect the

---

black battery cable to the NEGATIVE (-) terminal.

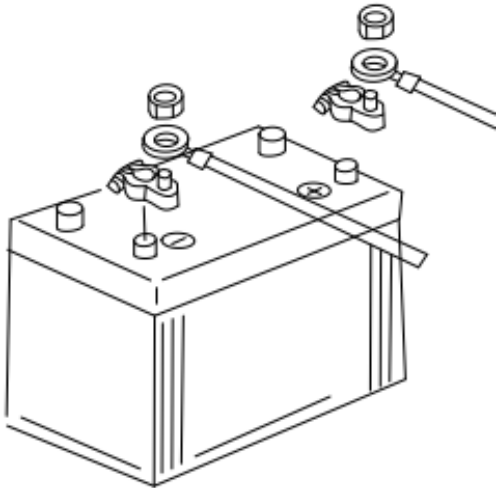

1. Red cable
2. Black cable
3. Battery

3. The electrical contacts of the battery and cables must be clean and properly connected, or the battery will not start the engine.

### **Disconnecting the battery**

1. Turn off the battery cut-off switch (if equipped) and main switch. *NOTICE:* If they are left on, the electrical system can be damaged.
2. Disconnect the negative cable(s) from the negative (-) terminal. *NOTICE:* Always disconnect all negative (-) cables first to avoid a short circuit and damage to the electrical system.
3. Disconnect the positive cable(s) and remove the battery from the boat.
4. Clean, maintain, and store the battery according to the manufacturer's instructions.

## **Trouble Recovery**

### **Troubleshooting**

A problem in the fuel, compression, or ignition systems can cause poor starting, loss of power, or other problem. This section describes basic checks and possible remedies, and covers all our outboard motors. Therefore some items may not apply to your model.

If your outboard motor require repair, bring it to your dealer.

If the engine trouble-alert indicator is flashing, consult your dealer.

#### **Starter will not operate.**

Q. Is battery capacity weak or low?

A. Check battery condition. Use battery of recommended capacity.

---

Q. Are battery connections loose or corroded?

A. Tighten battery cables and clean battery terminals.

Q. Is fuse for electric start relay or electric circuit blown?

A. Check for cause of electric overload and repair. Replace fuse with one of correct amperage.

Q. Are starter components faulty?

A. Have service by a dealer.

Q. Is shift lever in gear?

A. Shift to neutral.

**Engine will not start (starter operates)**

Q. Is fuel tank empty?

A. Fill tank with clean, fresh fuel.

Q. Is fuel contaminated or stale?

A. Fill tank with clean, fresh fuel.

---

Q. Is fuel filter clogged?

A. Clean or replace.

Q. Is starting procedure incorrect?

A. See page 62.

Q. Has fuel pump malfunctioned?

A. Have serviced by a dealer.

Q. Are sparks plug(s) fouled or of incorrect type?

A. Inspect spark plug(s). Clean or replace with recommended type.

Q. Are spark plug cap(s) fitted incorrectly?

A. Check and re-fit-cap(s).

Q. Is ignition wiring damaged or poorly connected?

A. Check wires for wear or breaks. Tighten all loose connections. Replace worn or broken wire.

Q. Are ignition parts faulty?

A. Have serviced by a dealer.

Q. Is engine shut-off cord (lanyard) not attached?

A. Attach cord.

Q. Are engine inner parts damaged?

A. Have serviced by a dealer.

### **Engine idles irregularly or stalls.**

Q. Are spark plug(s) fouled or of incorrect type?

A. Inspect spark plug(s). Clean or replace with recommended type.

Q. Is fuel system obstructed?

A. Check for pinched or kinked fuel line or other obstructions in fuel system.

Q. Is fuel contaminated or stale?

A. Fill tank with clean, fresh fuel.

Q. Is fuel filter clogged?

A. Clean or replace filter.

Q. Have ignition parts failed?

A. Have serviced by a dealer.

---

Q. Has alert system activated?

A. Find and correct cause of alert.

Q. Is spark plug gap incorrect?

A. Inspect and adjust as specified.

Q. Is ignition wiring damaged or poorly connected?

A. Check wires for wear or breaks. Tighten all loose connections. Replace worn or broken wires.

Q. Is specified engine oil not being used?

A. Check and replace oil as specified.

Q. Is thermostat faulty or clogged?

A. Have serviced by a dealer.

Q. Are carburetor adjustments incorrect?

A. Have serviced by a dealer?

Q. Is fuel pump damaged?

A. Have serviced by a dealer.

Q. Is air vent screw on fuel tank closed?

A. Open air vent screw.

Q. Is choke knob pulled out?

A. Return to home position.

Q. Is motor angle too high?

A. Return to normal operating position.

Q. Is carburetor clogged?

A. Have serviced by a dealer.

Q. Is fuel joint connection incorrect?

A. Connect correctly.

Q. Is throttle valve adjustment incorrect?

A. Have serviced by a dealer.

Q. Is battery cable disconnected?

A. Connect securely.

**Alert buzzer sounds or indicator lights.**

Q. Is cooling system clogged?

A. Check water intake for restriction.



---

Q. Is engine oil level low?

A. Fill oil tank with specified engine oil.

Q. Is heat range of spark plug incorrect?

A. Inspect spark plug and replace it with recommended type.

Q. Is specified engine oil not being used?

A. Check and replace oil with specified type.

Q. Is engine oil contaminated or deteriorated?

A. Replace oil with fresh, specified type.

Q. Is oil filter clogged?

A. Have serviced by a dealer.

Q. Has oil feed/injection pump malfunctioned?

A. Have serviced by a dealer.

Q. Is load on boat improperly distributed?

A. Distribute load to place boat on an even plane.

Q. Is water pump or thermostat faulty?

A. Have serviced by a dealer.

Q. Is there excess water in fuel filter cup?

A. Drain filter cup.

### **Engine power loss**

Q. Is propeller damaged?

A. Have propeller repaired or replace.

Q. Is propeller pitch or diameter incorrect?

A. Install correct propeller to operate outboard at its recommended speed (r/min) range.

Q. Is trim angle incorrect?

A. Adjust trim angle to achieve most efficient operation.

Q. Is motor mounted to proper transom height?

A. Clean boat bottom.

Q. Are spark plug(s) fouled or of incorrect type?

A. Inspect spark plug(S). Clean or replace with recommended types.

Q. Are weeds or other foreign matter tangled on gear housing?

A. Remove foreign matter and clean lower unit.

---

Q. Is fuel filter clogged?

A. Clean or replace filter.

Q. Is fuel contaminated or stale?

A. Fill tank with clean, fresh fuel.

Q. Is spark plug gap incorrect?

A. Inspect and adjust as specified.

Q. Is ignition wiring damaged or poorly connected?

A. Check wires for wear or breaks. Tighten all loose connections. Replace worn or broken wires.

Q. Have electrical parts failed?

A. Have serviced by a dealer.

Q. Is specified fuel not being used?

A. Replace fuel with specified type.

Q. Is specified engine oil not being used?

A. Check and replace oil with specified type.

Q. Is thermostat faulty or clogged?

A. Have serviced by a dealer.

Q. Is air vent screw closed?

A. Open the air vent screw.

Q. Is fuel pump damaged?

A. Have service by a dealer.

Q. Is fuel joint connection incorrect?

A. Connect correctly.

Q. Is heat range of spark plug incorrect?

A. Inspect spark plug and replace it with recommended type.

Q. Is high pressure fuel pump drive belt broken?

A. Have serviced by a dealer.

Q. Is engine not responding properly to shift lever position?

A. Have serviced by a dealer.

**Engine vibrates excessively.**

Q. Is propeller damaged?

A. Have propeller repaired or replace.

Q. Is propeller shaft damaged?

A. Have serviced by a dealer.

Q. Are weeds or other foreign matter tangled on propeller?

A. Remove and clean propeller.

Q. Is motor mounting bolt loose?

A. Tighten bolt.

Q. Is steering pivot loose or damaged?

A. Tighten or have serviced by a dealer.

### **Temporary action in emergency**

#### **Impact damage**



**The outboard motor can be seriously damaged by a collision while operating or trailering. Damage could make the outboard motor unsafe to operate.**

If the outboard motor hits an object in the water, follow the procedure below.



1. Stop the engine immediately.
2. Check the control system and oil components for damage. Also, check the boat for damage.
3. Whether damage is found or not, return to the nearest harbor slowly and carefully.
4. Have a dealer check the outboard motor before operating it again.

#### **Replacing fuse**

If a fuse has blown, open the fuse holder and remove the fuse with a fuse puller. Replace it with a spare one of the proper amperage.

**⚠ WARNING**

**Substituting an incorrect fuse or a piece of wire could allow excessive current flow. This could cause electric system damage and a fire hazard.**

Consult your dealer if the new fuse immediately blows again.

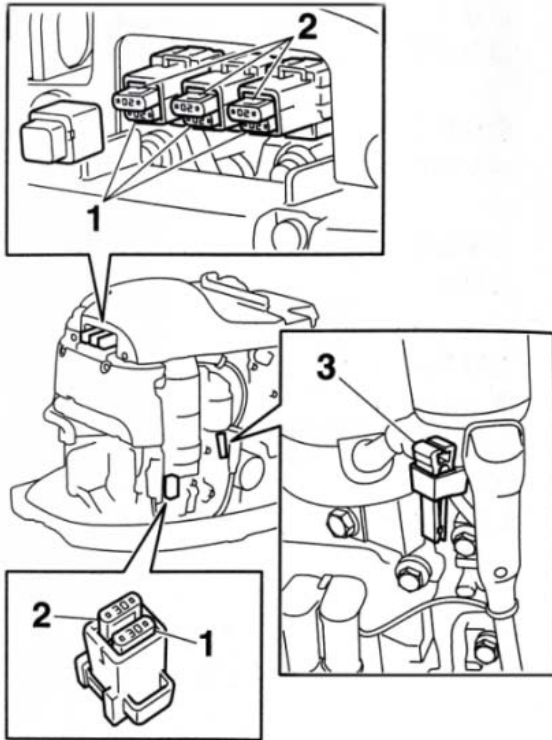

1. Fuse (20 A x 3, 30 A)
2. Spare fuse (20 A x 3, 30 A)
3. Fuse puller

**Power trim and tilt will not operation**

If the engine cannot be tilted up or down with the power trim and tilt because of a discharged battery or a failure with the power trim and tilt unit, the engine can be tilted manually.

1. Loosen the manual valve screw by turning it counterclockwise until it stops.

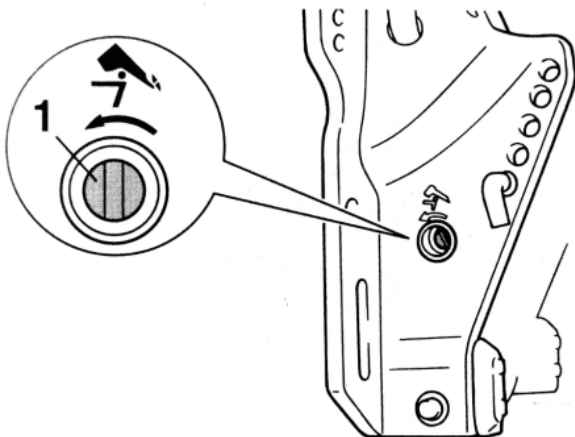

1. Manual valve screw

2. Put the engine in the desired position, then tighten the manual valve screw by turning it clockwise.

## Draining water in fuel filter



Gas is highly flammable, and its vapors are flammable and explosive.

- Do not perform this procedure on a hot or running engine, Allow the engine to cool.
- There will be fuel in the fuel filter. Keep away from sparks, cigarettes, flames or other sources of ignition.
- This procedure will allow some fuel to spill. Catch fuel in a reg. Wipe up any spilled fuel immediately.
- The fuel filter must be reassembled careful with the O- ring, filter cup, and hoses in place. Improper assembly or replacement could result in a fuel leak, which could result in a fire or explosion hazard.

If there is any water in the fuel filter, perform the following procedure.

1. Stop the engine.
2. Remove the top coving.
3. Remove the plastic tie.

### **Starter will not operation**

If the starter mechanism does not operate (the engine cannot be cranked with the starter), the engine can be started manually with an emergency starter rope. However, the engine cannot be started manually if the battery voltage is low. If th battery is discharged to 9 volts or below, the electric fuel pump will not operate. with an emergency starter rope.



- Use this procedure only in an emergency to return to the nearest port for repairs.
- When the emergency starter rope is used to start the engine, the start-in-gear protection device does not operate. Make sure the remote control level is in neutral. Otherwise the boat could unexpectedly start to move, which could result in an accident.
- Attach the engine shut-off cord to a secure place on your clothing, or your arm or leg while operating the boat.
- Do not attach the cord to clothing that could tear loose. Do not route the cord

where it could become entangled, preventing it from functioning.

- **Avoid accidentally pulling the cord during normal operation. Loss of engine power means the loss of most steering control. Also, without engine power, the boat could slow rapidly. This could cause people and objects in the boat to be thrown forward.**
- **Make sure no one is standing behind you when pulling the starter rope. It could whip behind you and injure someone.**
- **An unguarded, rotating flywheel is very dangerous. Keep loose clothing and other objects away when starting the engine. Use the emergency starter rope only as instructed. Do not touch the fly-wheel or other moving parts when the engine is running. Do not install the starter mechanism or top cowling after the engine is running.**
- **Do not touch the ignition coil, spark plug wire, spark plug cap, or other electrical components when starting or operating the motor. You could get an electrical shock.**

### **Emergency starting engine (manual starter model)**

1. Remove the top cowling.
2. Remove the starter/flywheel cover after removing the bolt.

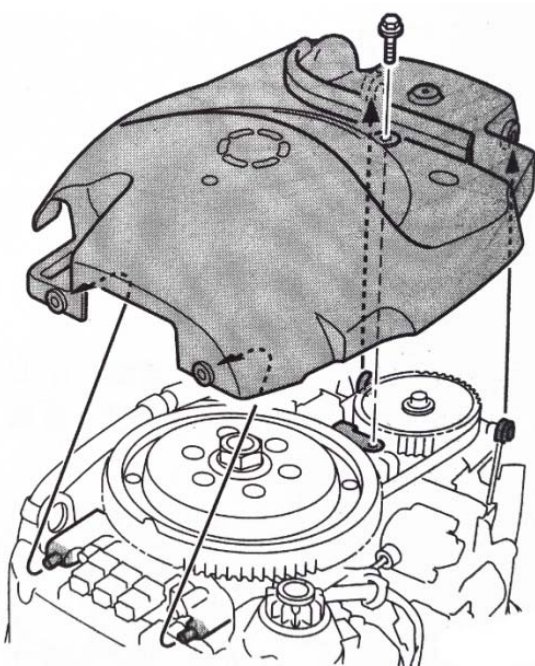

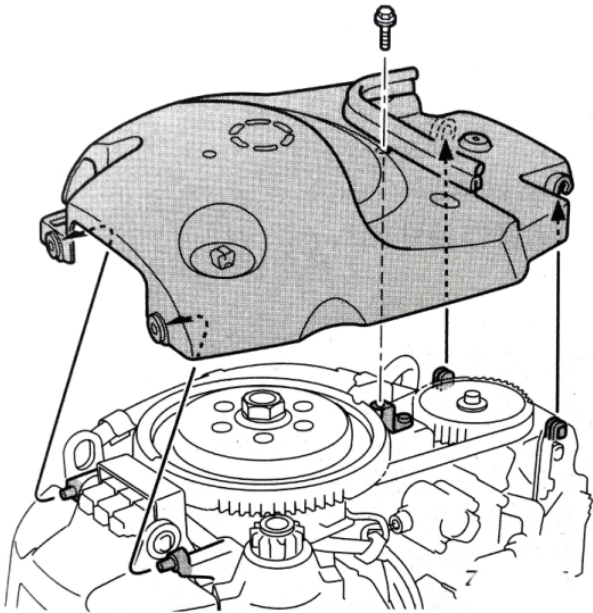

3. Prepare the engine for starting. Be sure that the gear shift is in neutral and that the clip is attached to the engine shut-off switch.

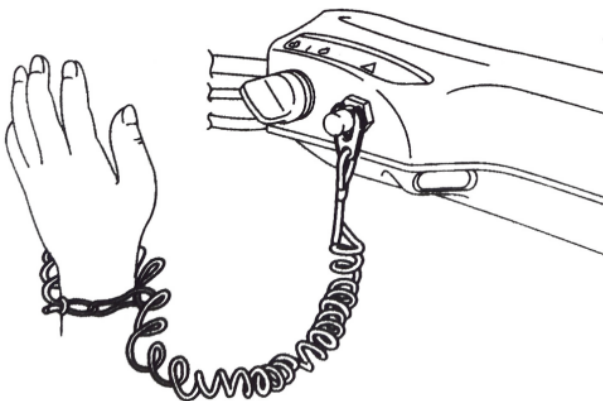
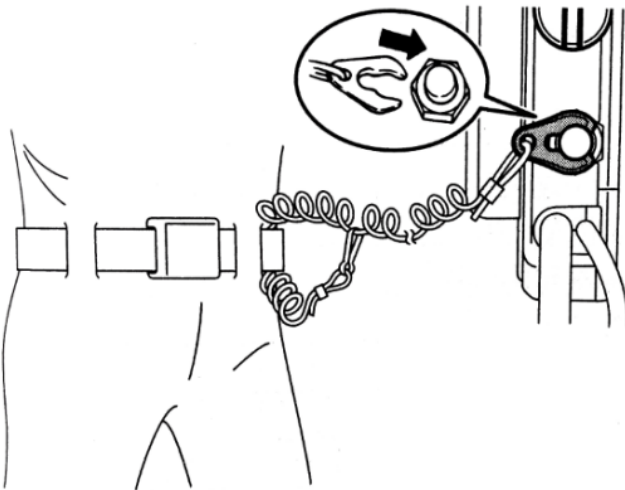

4. Turn on the main switch

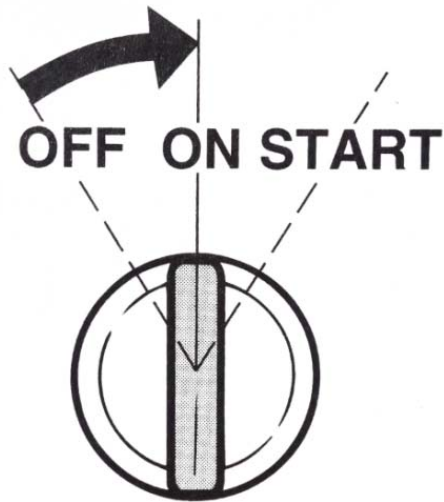

5. Insert the knotted end of the emergency starter rope into the notch in the flywheel rotor and wind the rope 1 or 2 turn(s) around the flywheel clockwise.
6. Give a strong pull straight out to crank the engine. Repeat if necessary. **WARNING!** Do not install the top coving when engine is running.

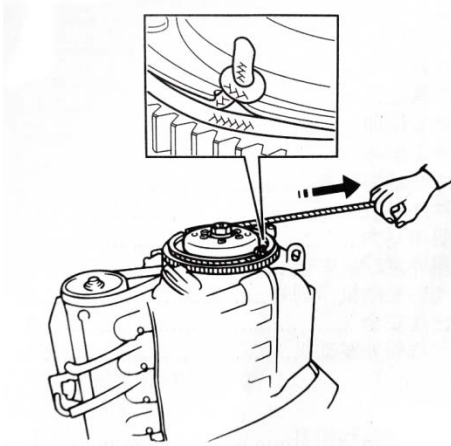

#### **Treatment of submerged motor**

If the outboard motor is submerged, immediately take it to a dealer. Otherwise some corrosion may begin almost immediately. **NOTICE: Do not attempt to run the outboard motor until it has been completely inspected.**